



MACRON DYNAMICS, INC.

PRODUCT
Datasheet

SPECIFICATIONS

Shipping Weight	12 lbs
Actuator Type	Macron 14H Linear Actuator
Maximum Speed	400 in/sec
Acceleration Exceeding	9 G's

MATERIALS

Cart Body	Aluminum
Rollers	Steel
Screws	Steel

Cart Assembly CSA-14H

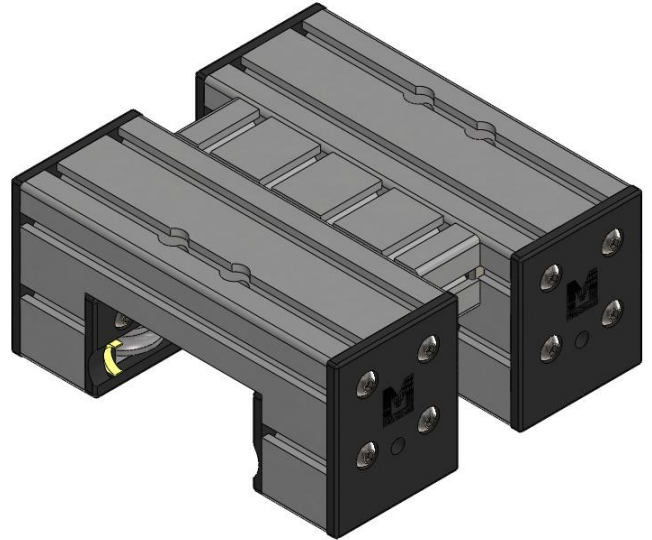

DIMENSIONS

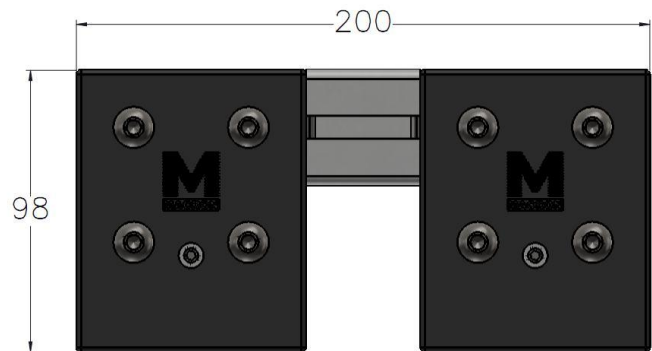
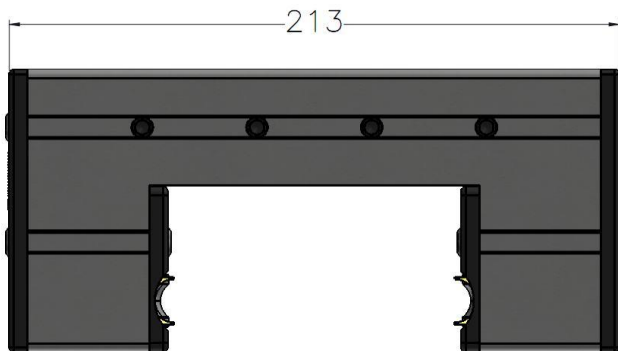

MACRON DYNAMICS, INC.
100 Phyllis Drive
Croydon, PA 19021

P: 215-443-8888
F: 215-443-0981
macron@macrondynamics.com

www.macrondynamics.com

Rev 01