

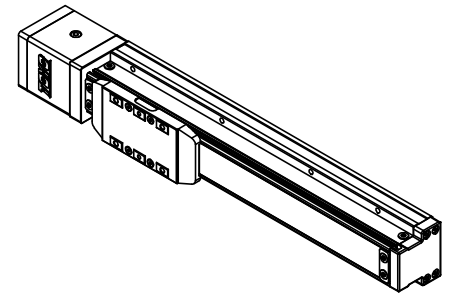

GTH5 SCREW TABLE SELECTION

GTH5-L___-___-BC-M10B-___

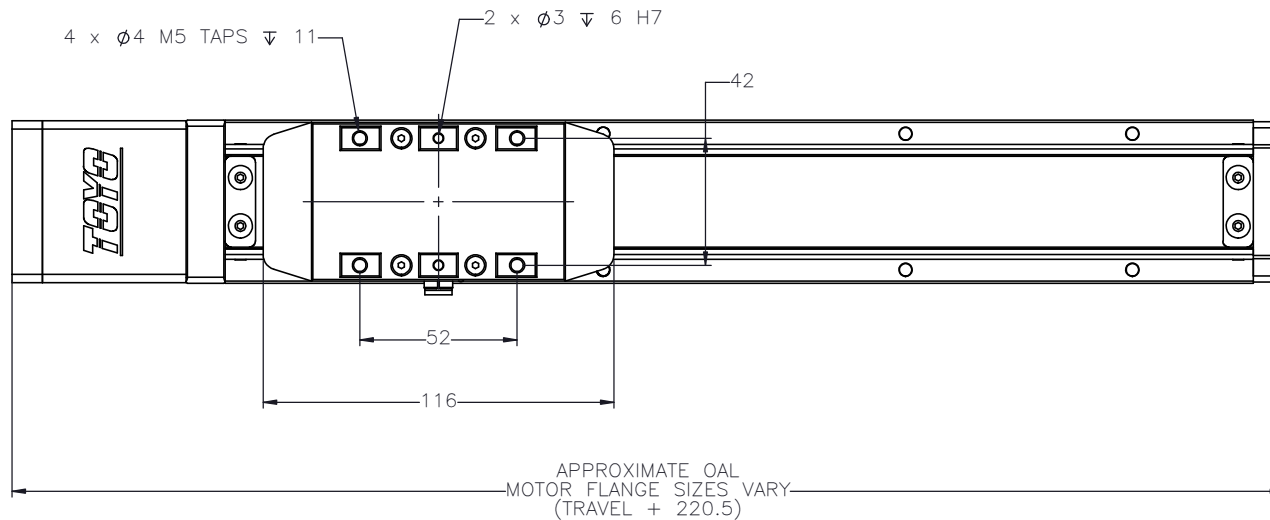

 MACRON DYNAMICS INC	DRAWN BY: AW DATE: 11/7/2023	MATERIAL:	TITLE: 10mm LEAD SCREW TABLE
	CHECKED BY: -- DATE: DD/MM/YYYY		
	LAST SAVED BY: awong DATE: 11/9/2023		
UNLESS OTHERWISE SPECIFIED: DIMENSIONS ARE IN MILLIMETERS TOLERANCES UNLESS NOTED OTHERWISE:	.X ± .762 .XX ± .254 .XXX ± .127 ANG ± 0°30'	FINISH:	SCALE: 1:1 SHEET SIZE: C
SURFACE FINISH 63	BREAK ALL SHARP EDGES DIMENSIONAL LIMITS APPLY AFTER FINISHING	SHEET 4 OF 7	
THIS DRAWING IS THE PROPERTY OF MACRON DYNAMICS ANY REPRODUCTIONS SHALL BE FOR QUOTATION, MANUFACTURING, OR PURCHASING PURPOSES ONLY. RELEASE OF DRAWINGS TO OTHER CONCERNS DOES NOT CONSTITUTE LICENSING IN ANY WAY. INFORMATION CONTAINED HEREIN IS PROPRIETARY AND CONFIDENTIAL.	THIRD ANGLE PROJECTION	PART NUMBER GTH5	