

GANTRY REPLACEMENT KITS

X-AXIS TRAVEL(mm) =

X GEARBOX SIZE =
(090 OR 120)

Z-AXIS TRAVEL(mm) =

Z GEARBOX SIZE =
(084 OR 114)

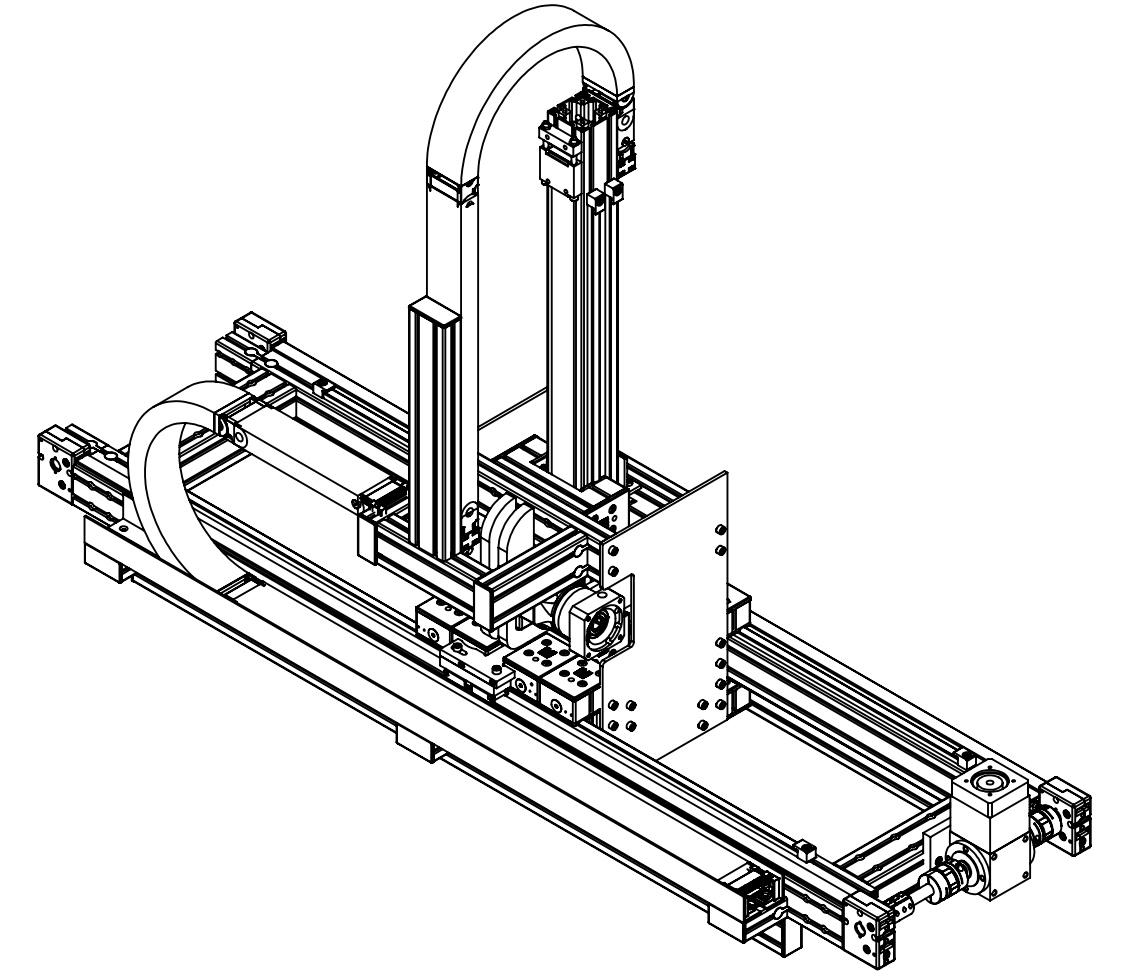
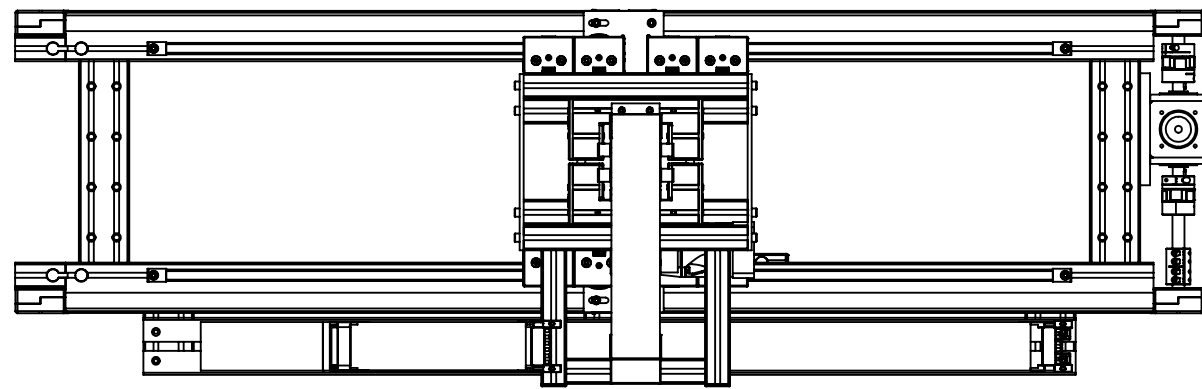

*VCT-090 GEARBOX AND MPG-084 GEARBOX SHOWN IN THIS SYSTEM

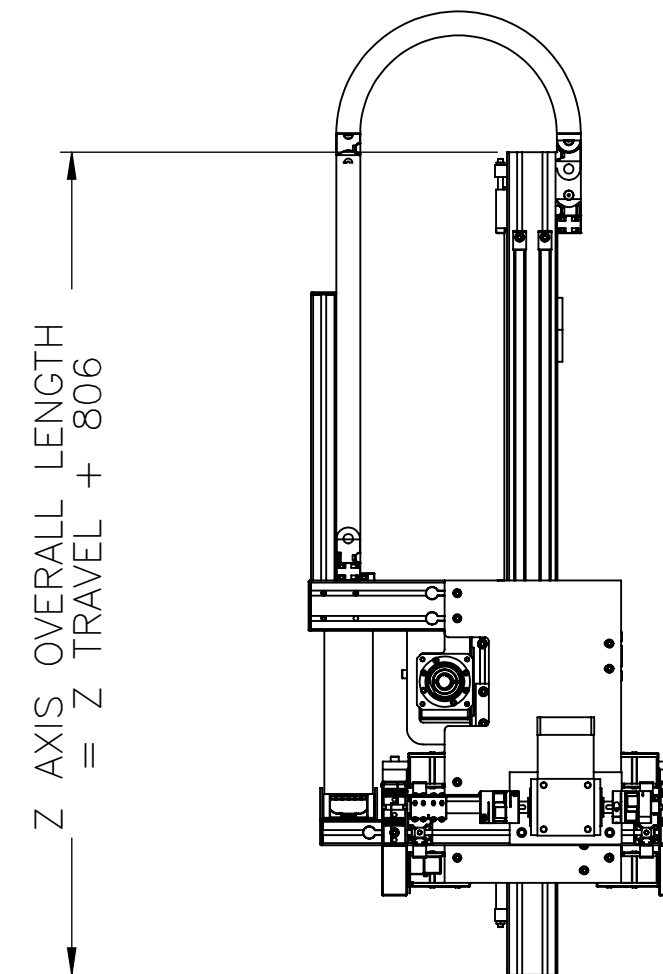
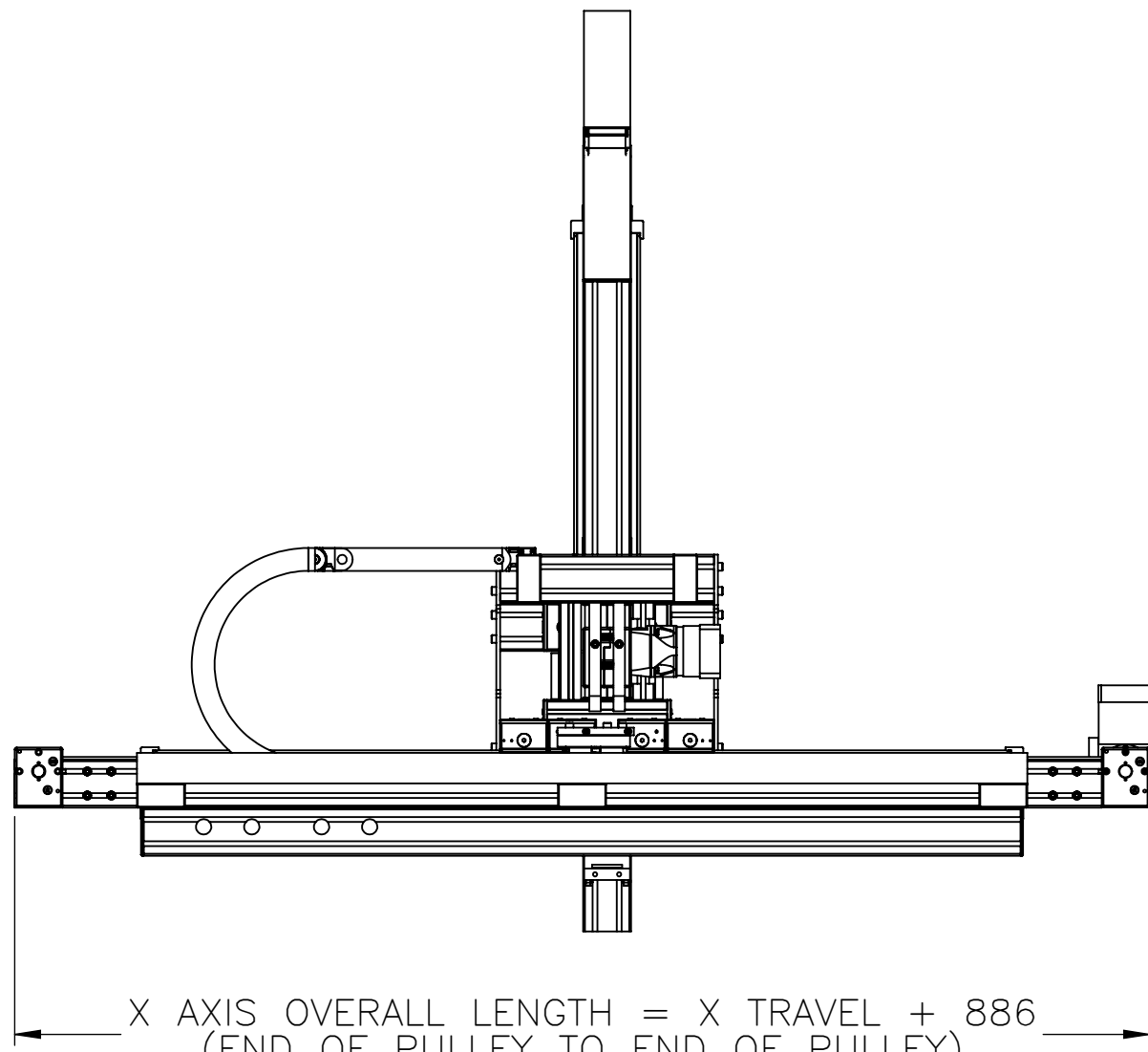

 MACRON DYNAMICS INC <small>THIS DRAWING IS THE PROPERTY OF MACRON DYNAMICS. ANY REPRODUCTIONS SHALL BE FOR QUOTATION, MANUFACTURING, OR PURCHASING PURPOSES ONLY. RELEASE OF DRAWINGS TO OTHER CONCERNS DOES NOT CONSTITUTE LICENSING IN ANY WAY. INFORMATION CONTAINED HEREIN IS PROPRIETARY AND CONFIDENTIAL.</small>		TITLE: UNIFIED CART GANTRY	
		THIRD ANGLE PROJECTION	SHEET 1 OF 11
UNLESS OTHERWISE SPECIFIED, DIMENSIONS ARE IN MILLIMETERS.	PART NUMBER UC2-XZ_VC-T-090_MPG-084_TEMPLATE	REV	

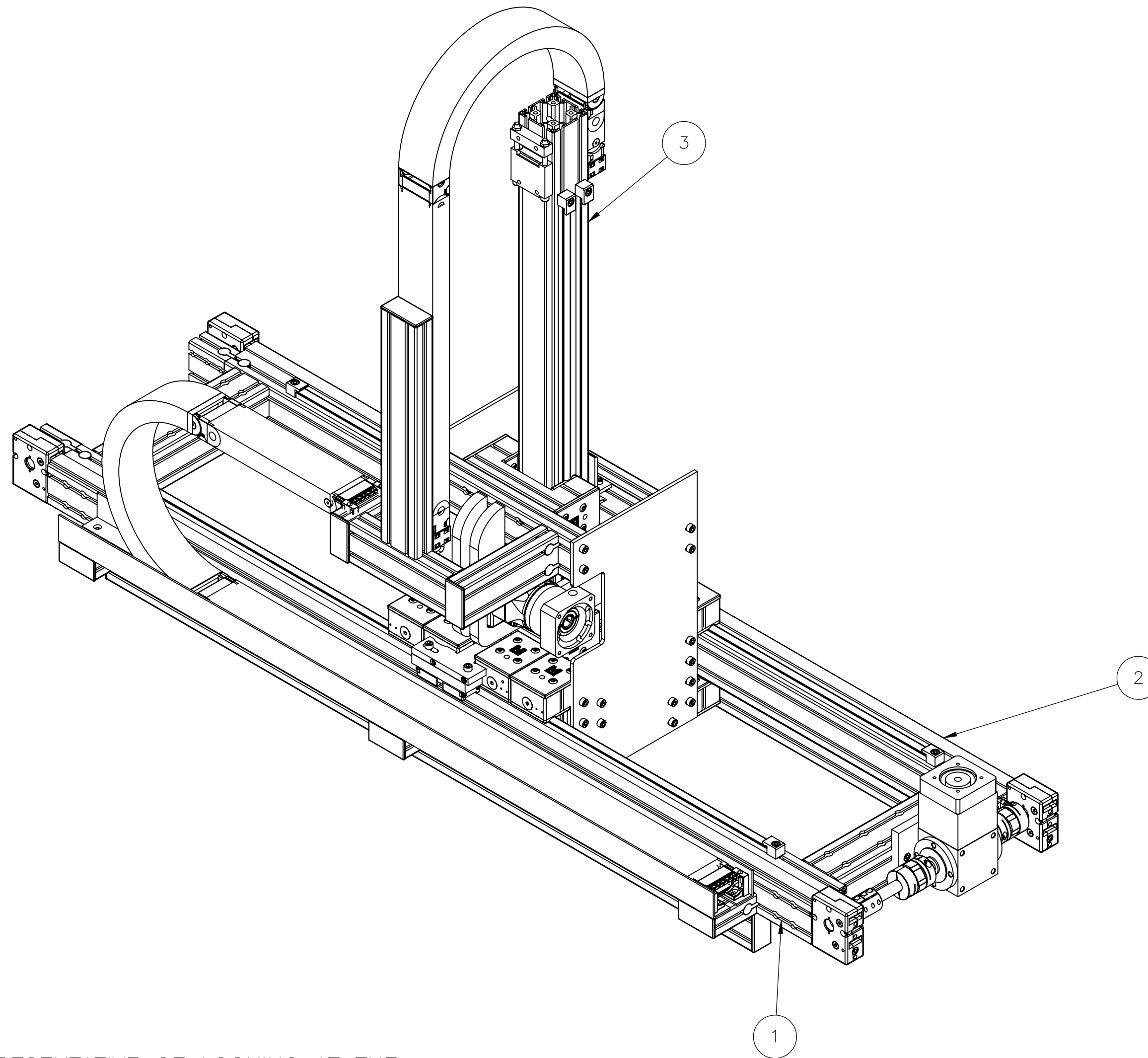

*ALL VIEWS IN THIS PACKAGE ARE REPRESENTATIVE OF LOOKING AT THE GANTRY FROM THE GEARBOX END.

**ALL DRAWINGS IN THIS PACKAGE ARE BASED OFF A VC-090 GEARBOX IN THE X AXIS AND AN MPG-084 GEARBOX IN THE Z AXIS. BE SURE TO REFERENCE THE TABLE ON EACH PAGE TO ENSURE YOU SELECT THE CORRECT DRIVE PULLEY FOR YOUR GEARBOX SIZE

ITEM	ITEM DESCRIPTION
1	X AXIS "LEFT" ACTUATOR
2	X AXIS "RIGHT" ACTUATOR
3	Z AXIS ACTUATOR

 MACRON DYNAMICS INC <small>THIS DRAWING IS THE PROPERTY OF MACRON DYNAMICS. ANY REPRODUCTIONS SHALL BE FOR QUOTATION, MANUFACTURING, OR PURCHASING PURPOSES ONLY. RELEASE OF DRAWINGS TO OTHER CONCERNS DOES NOT CONSTITUTE LICENSING IN ANY WAY. INFORMATION CONTAINED HEREIN IS PROPRIETARY AND CONFIDENTIAL.</small>	TITLE: UNIFIED CART GANTRY		
	THIRD ANGLE PROJECTION	SHEET 2 OF 11	LAST SAVED: 1/19/2023
UNLESS OTHERWISE SPECIFIED, DIMENSIONS ARE IN MILLIMETERS.	PART NUMBER UC2-XZ_VC-T-090_MPG-084_TEMPLATE	REV	

X AXIS "LEFT" ACTUATOR

P/N = GRK-UC2-XL- -

X GEARBOX SIZE (090 or 120)

X AXIS TRAVEL (mm)

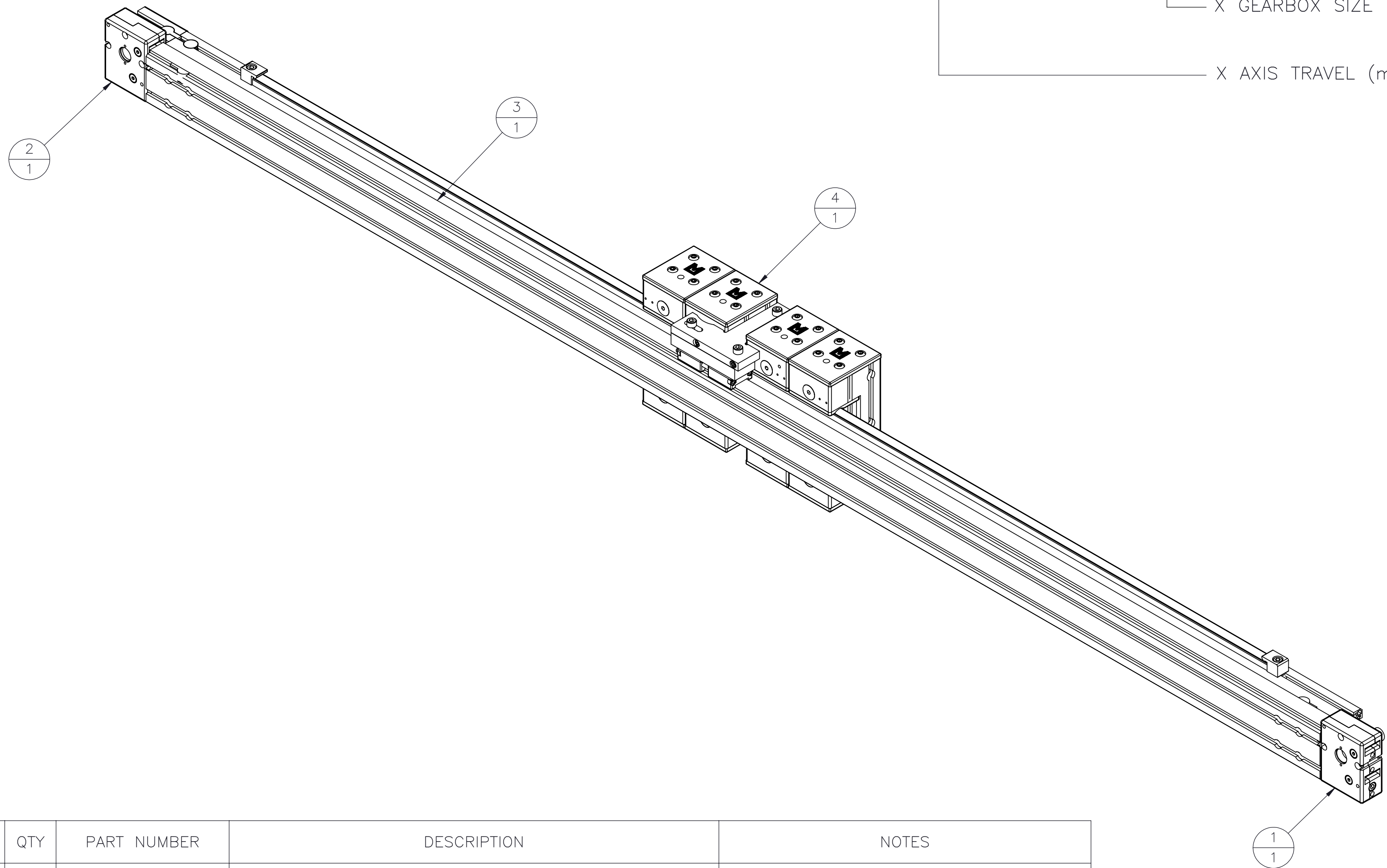

ITEM	QTY	PART NUMBER	DESCRIPTION	NOTES
1	1	PAS-BCS	SHAFTED PULLEY HOUSING ASSEMBLY KIT	<u>ONLY USED WITH VCT-090 GEARBOX</u>
	1	PAS-18464406	SHAFTED PULLEY HOUSING ASSEMBLY KIT	<u>ONLY USED WITH VCT-120 GEARBOX</u>
2	1	PAI-BCS	IDLER PULLEY HOUSING ASSEMBLY KIT	
3	1	DBK-CA-___	DRIVE BELT REPLACEMENT KIT	*BELT LENGTH = 1754 + 2(TRAVEL) *ROUND UP TO THE NEXT METER
4	1	GRK-UC2-XL-CSA	CART REPLACEMENT KIT-LEFT	



MACRON DYNAMICS INC

THIS DRAWING IS THE PROPERTY OF MACRON DYNAMICS. ANY REPRODUCTIONS SHALL BE FOR QUOTATION, MANUFACTURING, OR PURCHASING PURPOSES ONLY. RELEASE OF DRAWINGS TO OTHER CONCERNS DOES NOT CONSTITUTE LICENSING IN ANY WAY. INFORMATION CONTAINED HEREIN IS PROPRIETARY AND CONFIDENTIAL.

TITLE: **MACRON 14F ROTATED ACTUATOR**

THIRD ANGLE PROJECTION	PART NUMBER	SHEET 3 OF 11	LAST SAVED: 1/19/2023
UNLESS OTHERWISE SPECIFIED, DIMENSIONS ARE IN MILLIMETERS.		MRC-14H-A-1500	REV

X AXIS "LEFT" ACTUATOR CART ASSEMBLY

P/N = GRK-UC2-XL-CSA

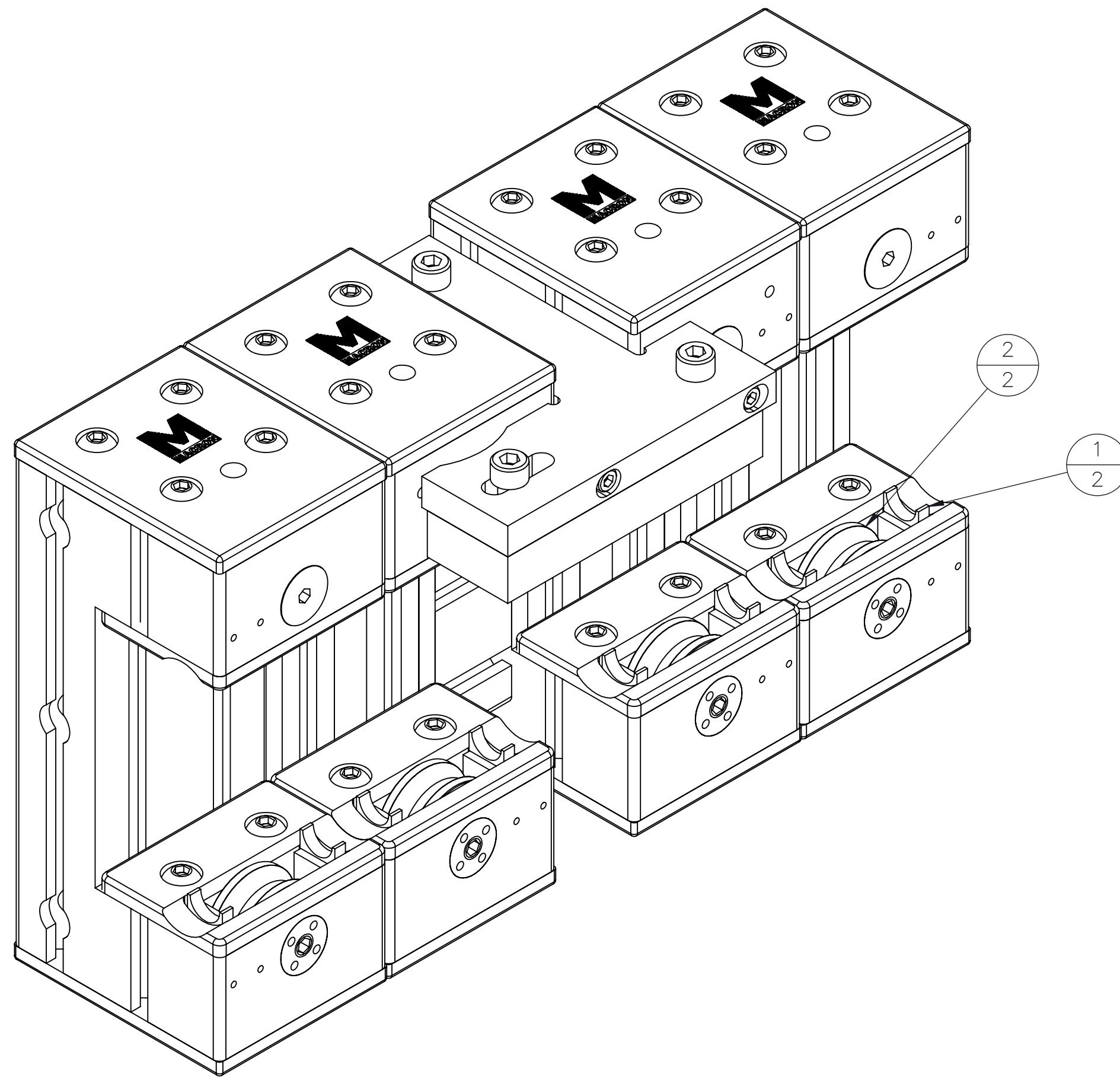

ITEM	QTY	PART NUMBER	DESCRIPTION
1	2	WRK-14H	WIPER REPLACEMENT KIT
2	2	RLK-14S	ROLLER REPLACEMENT KIT

 MACRON DYNAMICS INC <small>THIS DRAWING IS THE PROPERTY OF MACRON DYNAMICS. ANY REPRODUCTIONS SHALL BE FOR QUOTATION, MANUFACTURING, OR PURCHASING PURPOSES ONLY. RELEASE OF DRAWINGS TO OTHER CONCERNS DOES NOT CONSTITUTE LICENSING IN ANY WAY. INFORMATION CONTAINED HEREIN IS PROPRIETARY AND CONFIDENTIAL.</small>	TITLE: MACRON 14 HD EXTENDED DBB CART, 14in	
	THIRD ANGLE PROJECTION	SHEET 4 OF 11 LAST SAVED: 1/19/2023
<small>UNLESS OTHERWISE SPECIFIED, DIMENSIONS ARE IN MILLIMETERS.</small>	PART NUMBER CSA-14F-L	REV

X AXIS "RIGHT" ACTUATOR

P/N = GRK-UC2-XR-

-

X GEARBOX SIZE (090 or 120)

X AXIS TRAVEL (mm)

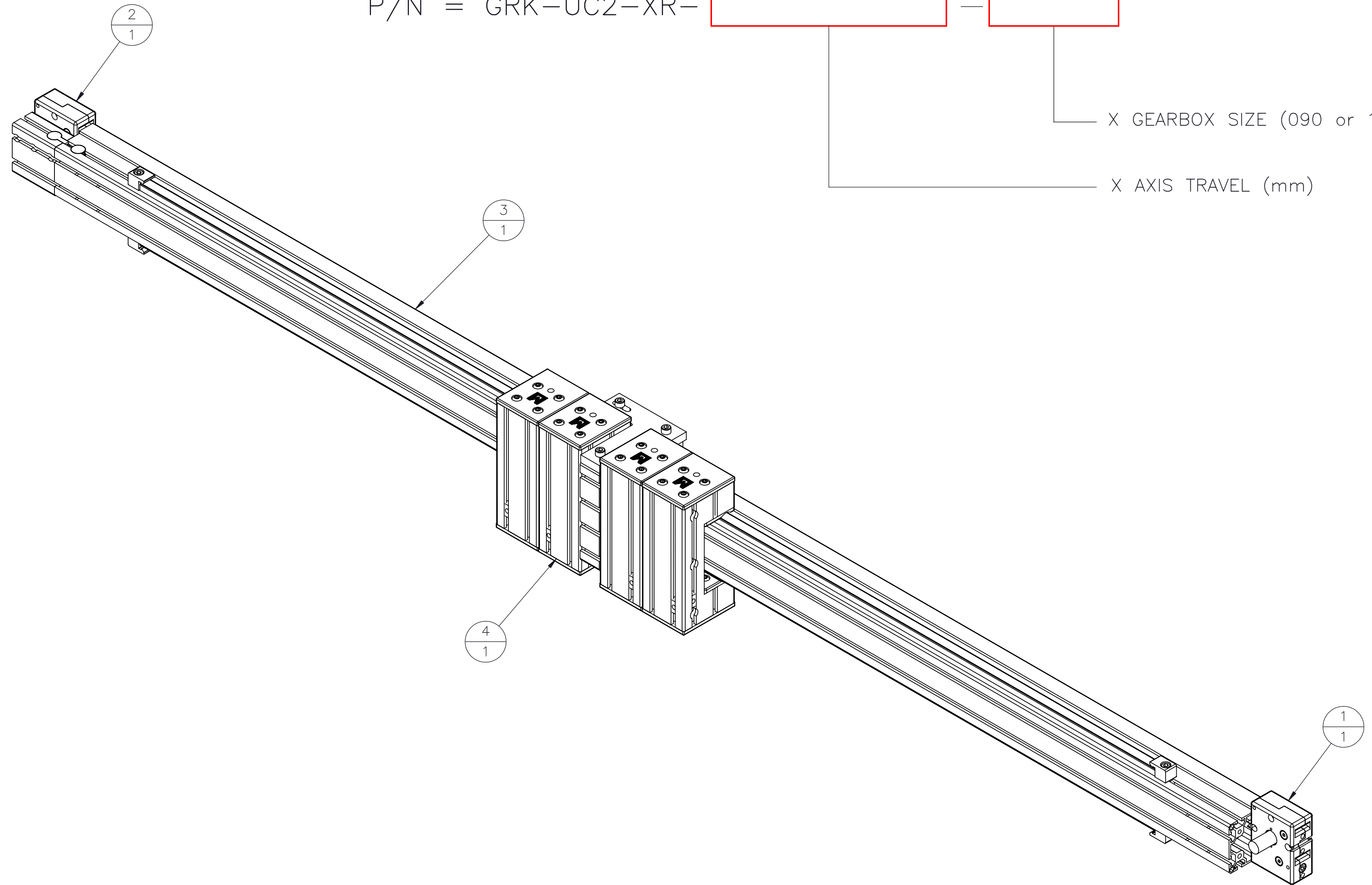

ITEM	QTY	PART NUMBER	DESCRIPTION	NOTES
1	1	PAS-BCS	SHAFTED PULLEY HOUSING ASSEMBLY KIT	ONLY USED WITH VCT-090 GEARBOX
	1	PAS-18464406	SHAFTED PULLEY HOUSING ASSEMBLY KIT	ONLY USED WITH VCT-120 GEARBOX
2	1	PAI-BCS	IDLER PULLEY HOUSING ASSEMBLY KIT	
3	1	DBK-CA-___	DRIVE BELT REPLACEMENT KIT	*BELT LENGTH=1754+2(TRAVEL) *ROUND UP TO THE NEXT METER
4	1	GRK-UC2-XR-CSA	CART REPLACEMENT KIT-RIGHT	



MACRON DYNAMICS INC

THIS DRAWING IS THE PROPERTY OF MACRON DYNAMICS. ANY REPRODUCTIONS SHALL BE FOR QUOTATION, MANUFACTURING, OR PURCHASING PURPOSES ONLY. RELEASE OF DRAWINGS TO OTHER CONCERNS DOES NOT CONSTITUTE LICENSING IN ANY WAY. INFORMATION CONTAINED HEREIN IS PROPRIETARY AND CONFIDENTIAL.

TITLE: MACRON 14F ROTATED ACTUATOR

THIRD ANGLE PROJECTION	SHEET 5 OF 11	LAST SAVED: 1/19/2023
UNLESS OTHERWISE SPECIFIED, DIMENSIONS ARE IN MILLIMETERS.	PART NUMBER	REV
	MRC-14H-B-1500	

X AXIS "RIGHT" ACTUATOR CART ASSEMBLY

P/N = GRK-UC2-XR-CSA

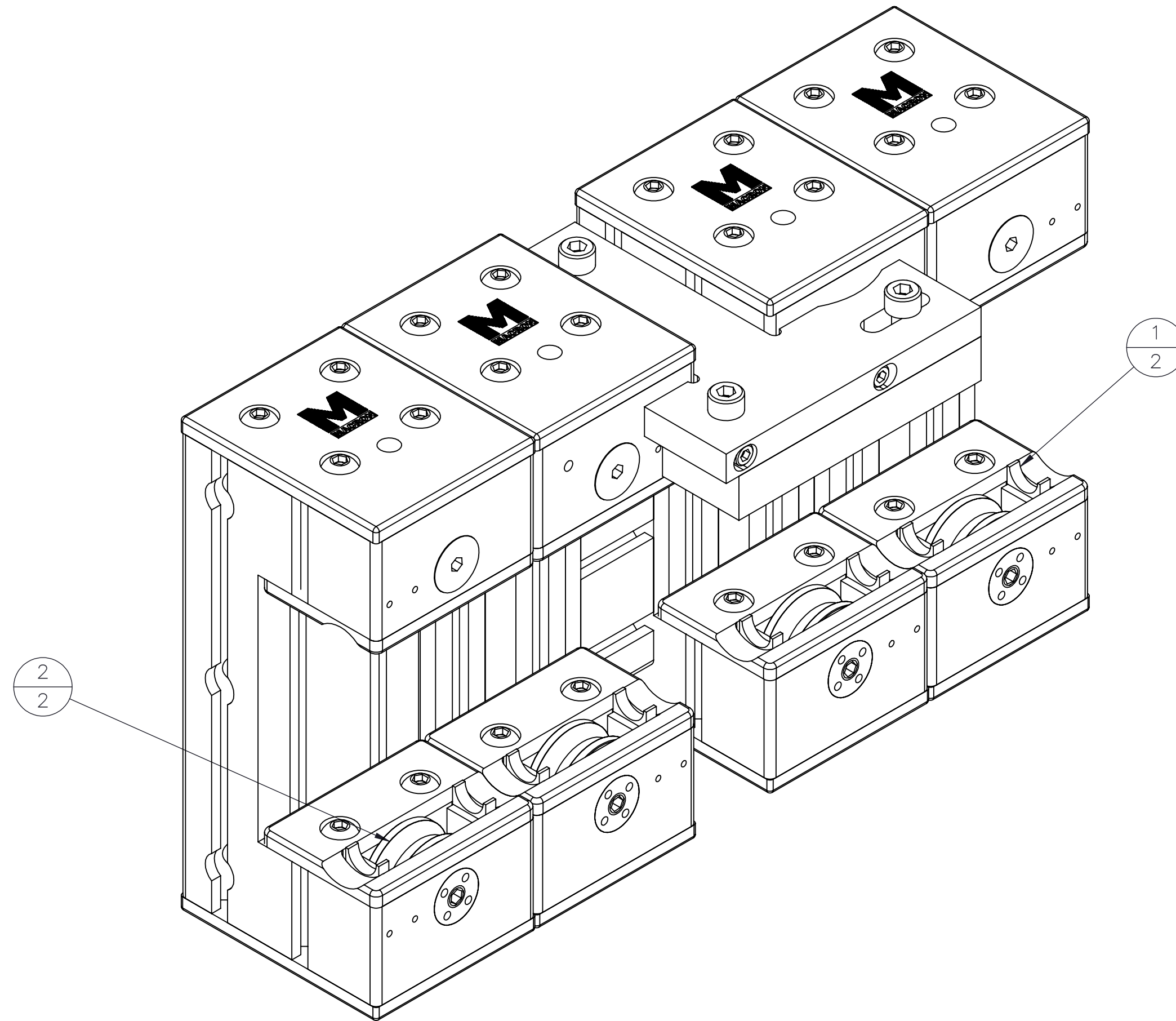

ITEM	QTY	PART NUMBER	DESCRIPTION
1	2	WRK-14H	WIPER REPLACEMENT KIT
2	2	RLK-14S	ROLLER REPLACEMENT KIT

 MACRON DYNAMICS INC <small>THIS DRAWING IS THE PROPERTY OF MACRON DYNAMICS. ANY REPRODUCTIONS SHALL BE FOR QUOTATION, MANUFACTURING, OR PURCHASING PURPOSES ONLY. RELEASE OF DRAWINGS TO OTHER CONCERNS DOES NOT CONSTITUTE LICENSING IN ANY WAY. INFORMATION CONTAINED HEREIN IS PROPRIETARY AND CONFIDENTIAL.</small>	TITLE: MACRON 14 HD EXTENDED DBB CART, 14in	
	THIRD ANGLE PROJECTION <small>UNLESS OTHERWISE SPECIFIED, DIMENSIONS ARE IN MILLIMETERS.</small>	PART NUMBER CSA-14F-R

Z AXIS ACTUATOR

P/N = GRK-UC2-Z0- -

Z GEARBOX SIZE (084 or 114)

Z AXIS TRAVEL (mm)

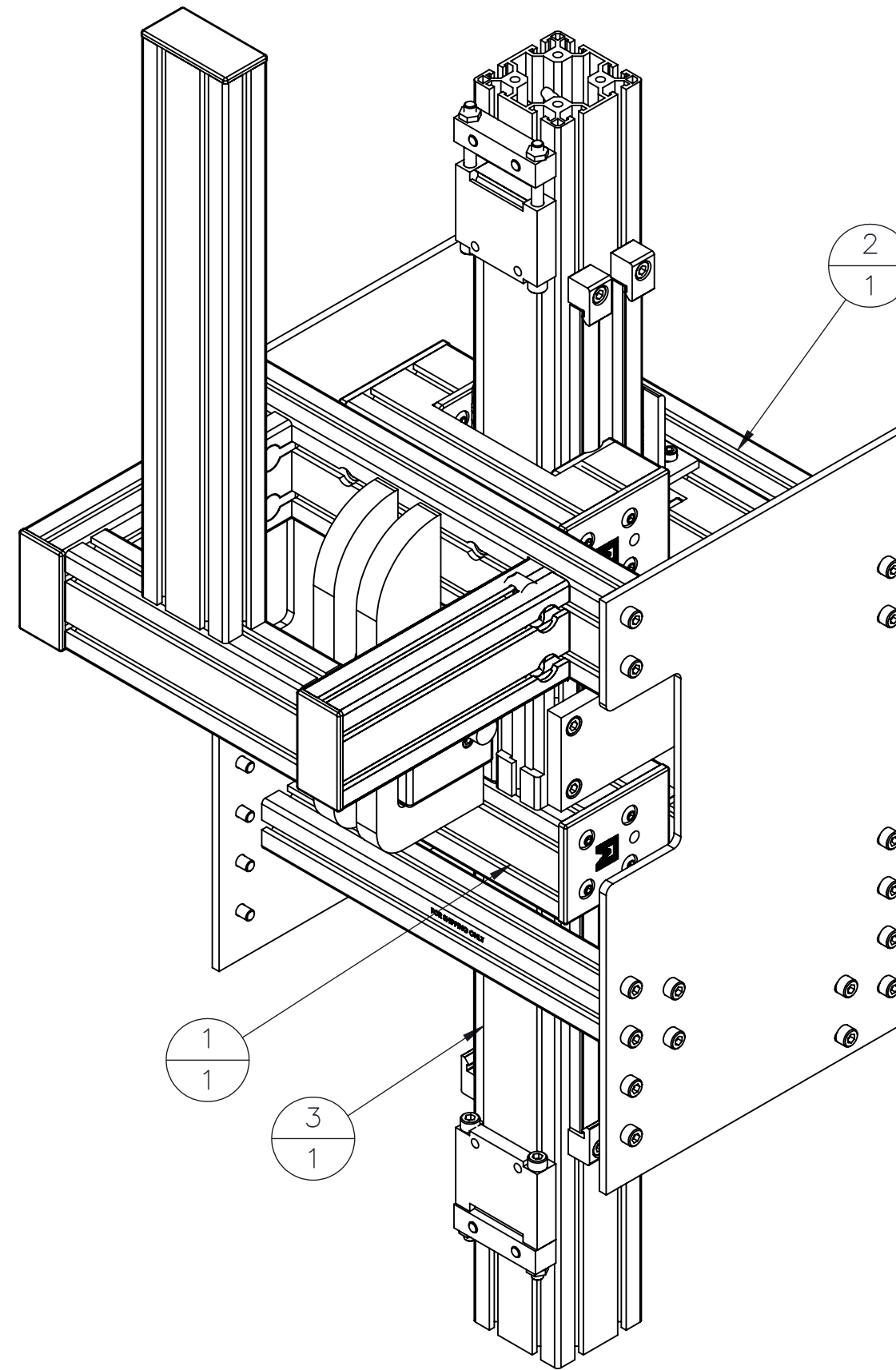

ITEM	QTY	PART NUMBER	DESCRIPTION	NOTES
1	1	GRK-UC2-Z0-DCA	DRIVE REPLACEMENT CART	<u>ONLY USED WITH MPG/MRG-084 GEARBOX</u>
	1	CSA-14Z-50-118-2X	DRIVE REPLACEMENT CART	<u>ONLY USED WITH MPG/MRG-114 GEARBOX</u>
2	1	GRK-UC2-Z0-ICA	IDLER REPLACEMENT CART	
3	1	DBK-EB-__	DRIVE BELT REPLACEMENT KIT	*BELT LENGTH = TRAVEL + 850 *ROUND TO THE NEAREST METER

 MACRON DYNAMICS INC <small>THIS DRAWING IS THE PROPERTY OF MACRON DYNAMICS. ANY REPRODUCTIONS SHALL BE FOR QUOTATION, MANUFACTURING, OR PURCHASING PURPOSES ONLY. RELEASE OF DRAWINGS TO OTHER CONCERNS DOES NOT CONSTITUTE LICENSING IN ANY WAY. INFORMATION CONTAINED HEREIN IS PROPRIETARY AND CONFIDENTIAL.</small>	TITLE: UNIFIED CART GANTRY	
	THIRD ANGLE PROJECTION	SHEET 7 OF 11
UNLESS OTHERWISE SPECIFIED, DIMENSIONS ARE IN MILLIMETERS.	PART NUMBER MSA-14H-C, MGS-UC2	LAST SAVED: 1/19/2023 REV

Z AXIS ACTUATOR DRIVE CART ASSEMBLY

P/N = GRK-UC2-Z0-DCA

*ONLY USED WITH MPG/MRG-084 GEARBOX

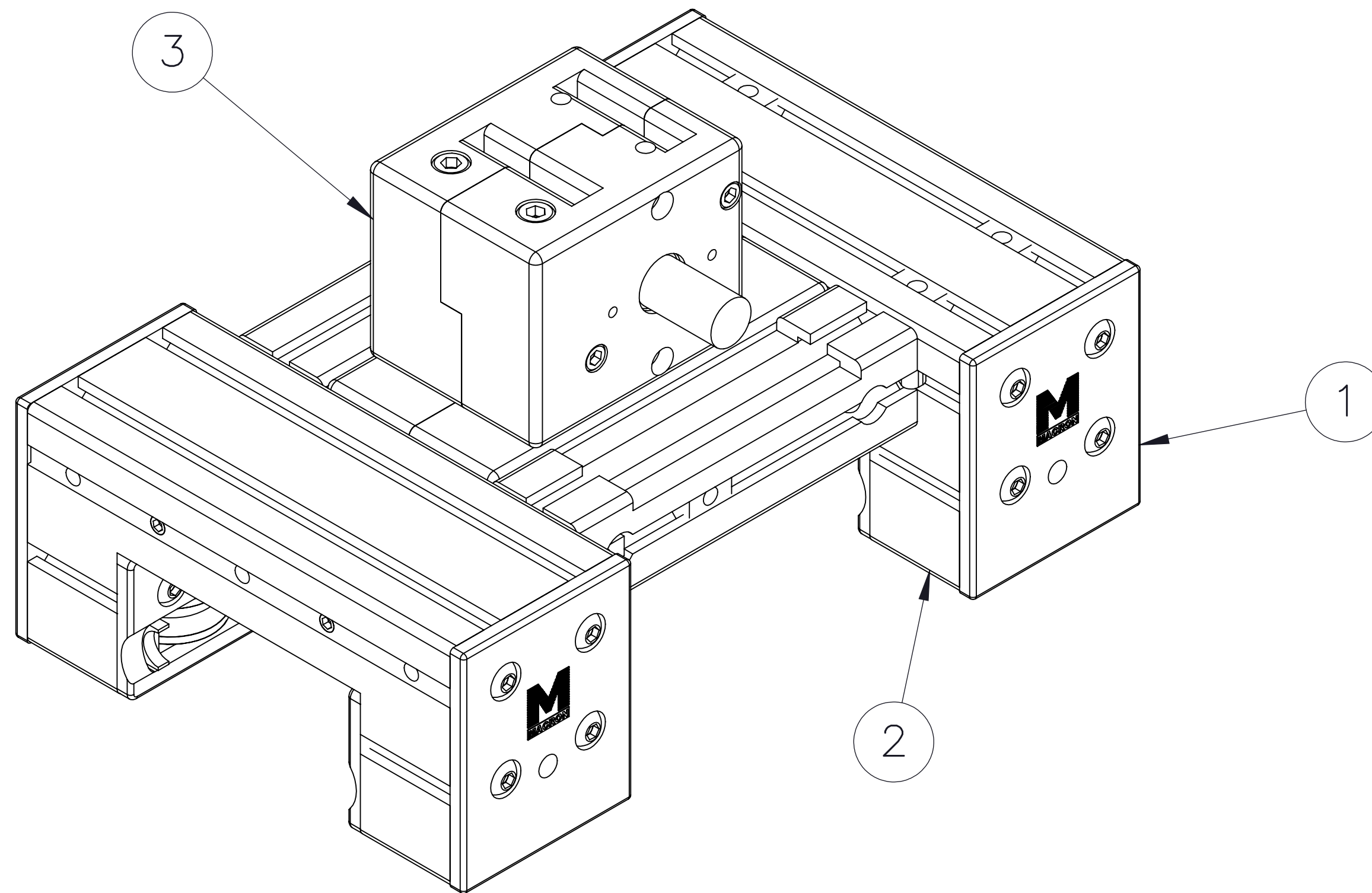

ITEM	QTY	PART NUMBER	DESCRIPTION
1	1	WRK-14H	WIPER REPLACEMENT KIT
2	1	RLK-14S	ROLLER REPLACEMENT KIT
3	1	PAS-BES	SHAFTED PULLEY HOUSING ASSEMBLY KIT

 MACRON DYNAMICS INC <small>THIS DRAWING IS THE PROPERTY OF MACRON DYNAMICS. ANY REPRODUCTIONS SHALL BE FOR QUOTATION, MANUFACTURING, OR PURCHASING PURPOSES ONLY. RELEASE OF DRAWINGS TO OTHER CONCERNS DOES NOT CONSTITUTE LICENSING IN ANY WAY. INFORMATION CONTAINED HEREIN IS PROPRIETARY AND CONFIDENTIAL.</small>	TITLE: DRIVE CART ASSEMBLY
THIRD ANGLE PROJECTION	SHEET 8 OF 11 LAST SAVED: 1/19/2023
UNLESS OTHERWISE SPECIFIED, DIMENSIONS ARE IN MILLIMETERS.	PART NUMBER: 13193426 REV: 02

Z AXIS ACTUATOR DRIVE CART ASSEMBLY

P/N = CSA-14Z-50-118-2X

*ONLY USED WITH MPG/MRG-114 GEARBOX

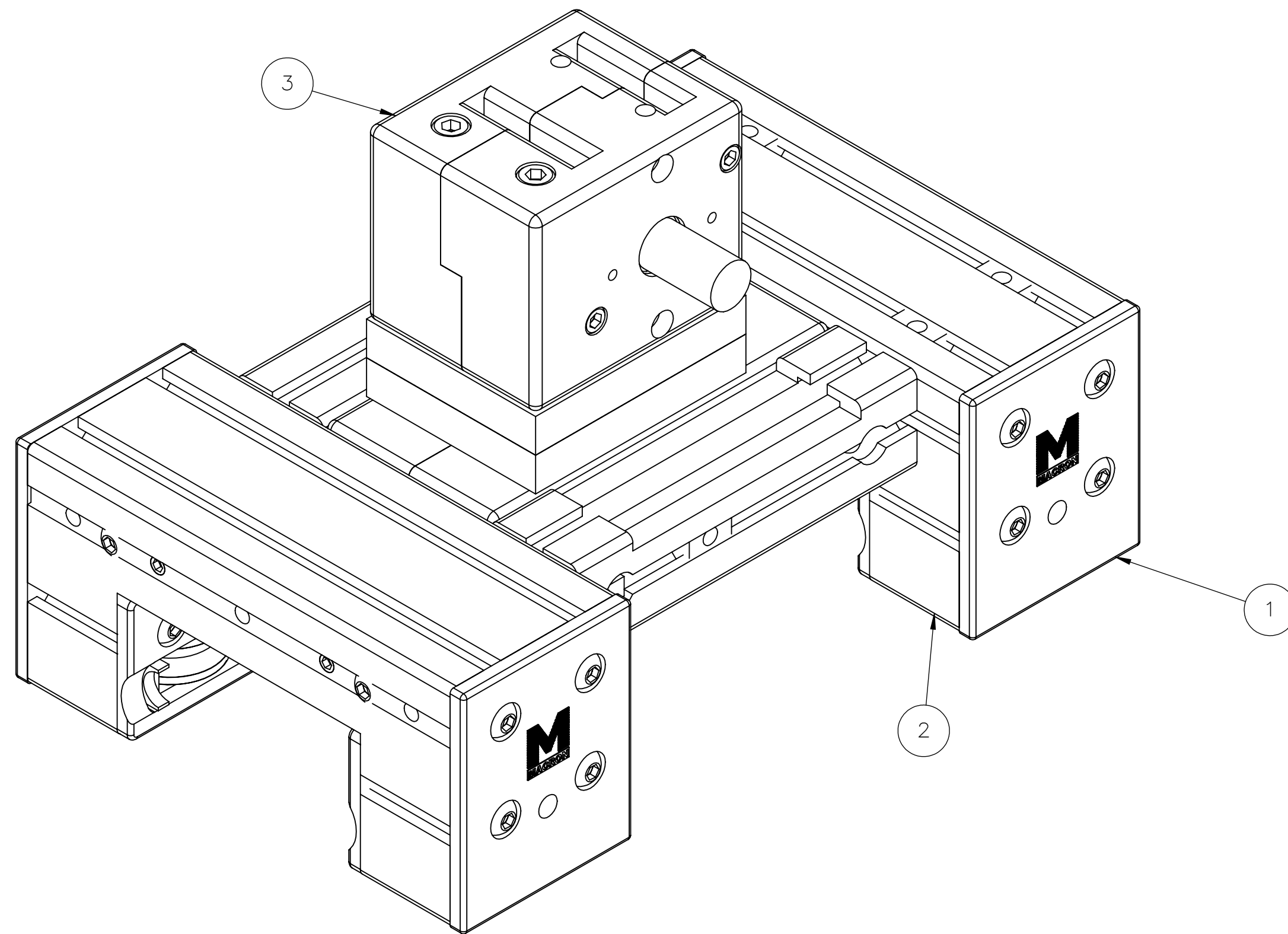

ITEM	QTY	PART NUMBER	DESCRIPTION
1	1	WRK-14H	WIPER REPLACEMENT KIT
2	1	RLK-14S	ROLLER REPLACEMENT KIT
3	1	PAS-BES	SHAFTED PULLEY HOUSING ASSEMBLY KIT

 MACRON DYNAMICS INC <small>THIS DRAWING IS THE PROPERTY OF MACRON DYNAMICS. ANY REPRODUCTIONS SHALL BE FOR QUOTATION, MANUFACTURING, OR PURCHASING PURPOSES ONLY. RELEASE OF DRAWINGS TO OTHER CONCERNS DOES NOT CONSTITUTE LICENSING IN ANY WAY. INFORMATION CONTAINED HEREIN IS PROPRIETARY AND CONFIDENTIAL.</small>	TITLE: 14Z HD Z-CART FOR 118 GB
THIRD ANGLE PROJECTION <small>UNLESS OTHERWISE SPECIFIED, DIMENSIONS ARE IN MILLIMETERS.</small>	SHEET 9 OF 11 PART NUMBER CSA-14Z-50-118-2X
LAST SAVED: 1/19/2023 REV	

Z AXIS ACTUATOR IDLER CART ASSEMBLY

P/N = GRK-UC2-Z0-ICA

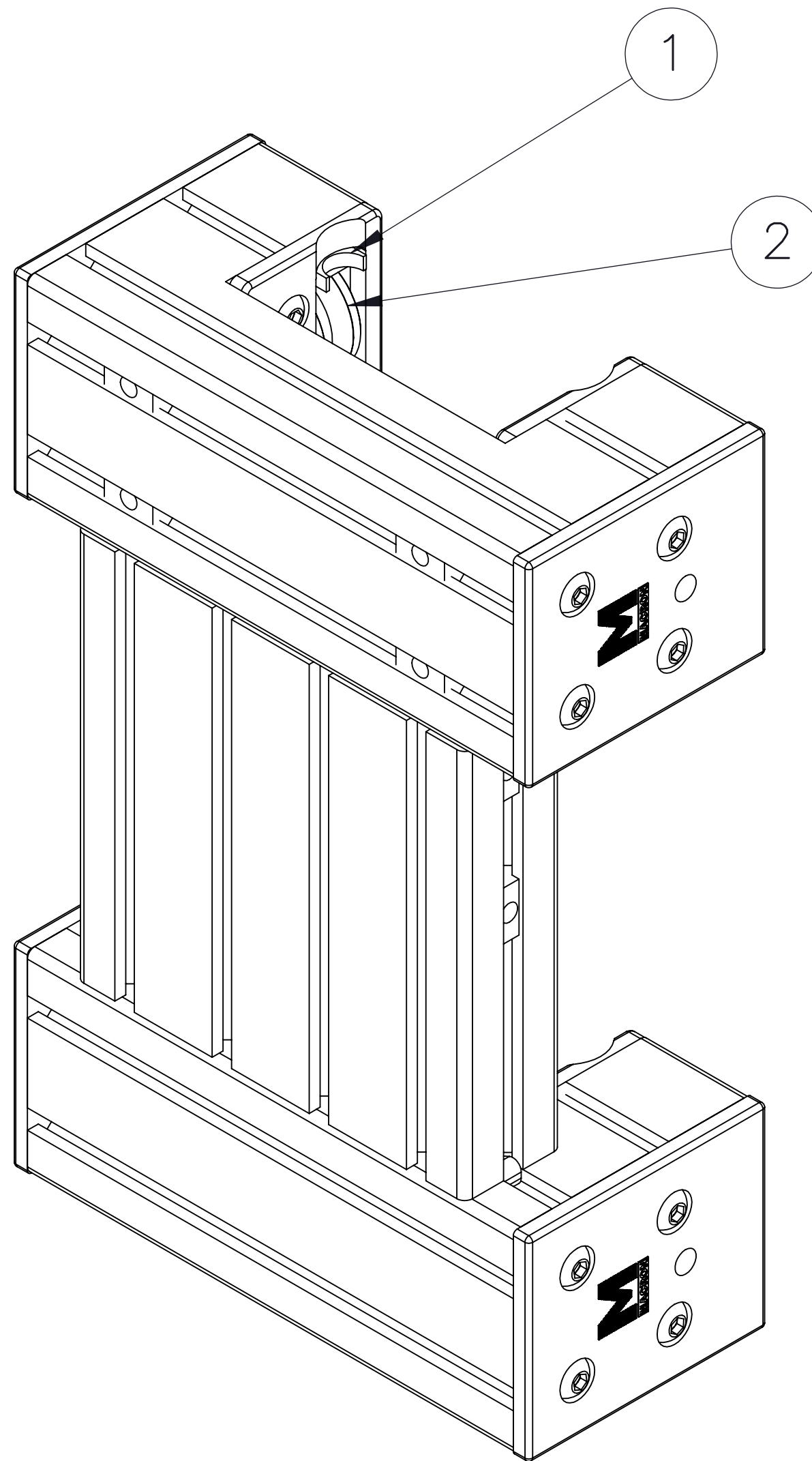

ITEM	QTY	PART NUMBER	DESCRIPTION
1	1	WRK-14H	WIPER REPLACEMENT KIT
2	1	RLK-14S	ROLLER REPLACEMENT KIT

 MACRON DYNAMICS INC <small>THIS DRAWING IS THE PROPERTY OF MACRON DYNAMICS. ANY REPRODUCTIONS SHALL BE FOR QUOTATION, MANUFACTURING, OR PURCHASING PURPOSES ONLY. RELEASE OF DRAWINGS TO OTHER CONCERNS DOES NOT CONSTITUTE LICENSING IN ANY WAY. INFORMATION CONTAINED HEREIN IS PROPRIETARY AND CONFIDENTIAL.</small>	TITLE: 14H Z CART ASSEMBLY	
	THIRD ANGLE PROJECTION	SHEET 10 OF 11
<small>UNLESS OTHERWISE SPECIFIED, DIMENSIONS ARE IN MILLIMETERS.</small>	PART NUMBER 13193415	REV 02

AVAILABLE GANTRY REPLACEMENT KITS

X AXIS REPLACEMENT KITS

PART NUMBER	DESCRIPTION
PAS-BCS*	SHAFTED PULLEY HOUSING ASSEMBLY KIT
PAS-18464406**	SHAFTED PULLEY HOUSING ASSEMBLY KIT
PAI-BCS	IDLER PULLEY HOUSING ASSEMBLY KIT
DBK-CA-__	DRIVE BELT REPLACEMENT KIT
WRK-14H	WIPER REPLACEMENT KIT
RLK-14S	ROLLER REPLACEMENT KIT
GRK-UC2-XL-CSA	CART REPLACEMENT KIT-LEFT
GRK-UC2-XR-CSA	CART REPLACEMENT KIT-RIGHT

Z AXIS REPLACEMENT KITS

PART NUMBER	DESCRIPTION
PAS-BES	SHAFTED PULLEY HOUSING ASSEMBLY KIT
GRK-UC2-ZO-DCA***	DRIVE REPLACEMENT CART
CSA-14Z-50-118-2X****	DRIVE REPLACEMENT CART
GRK-UC2-ZO-ICA	IDLER REPLACEMENT CART
DBK-EB-__	DRIVE BELT REPLACEMENT KIT
WRK-14H	WIPER REPLACEMENT KIT
RLK-14S	ROLLER REPLACEMENT KIT

* ONLY USED WITH VCT-090 GEARBOX

** ONLY USED WITH VCT-120 GEARBOX

*** ONLY USED WITH MPG/MRG-084 GEARBOX

**** ONLY USED WITH MPG-MRG-114 GEARBOX

 MACRON DYNAMICS INC <small>THIS DRAWING IS THE PROPERTY OF MACRON DYNAMICS. ANY REPRODUCTIONS SHALL BE FOR QUOTATION, MANUFACTURING, OR PURCHASING PURPOSES ONLY. RELEASE OF DRAWINGS TO OTHER CONCERNS DOES NOT CONSTITUTE LICENSING IN ANY WAY. INFORMATION CONTAINED HEREIN IS PROPRIETARY AND CONFIDENTIAL.</small>	TITLE:	
	THIRD ANGLE PROJECTION	SHEET 11 OF 11 LAST SAVED: 1/19/2023
UNLESS OTHERWISE SPECIFIED, DIMENSIONS ARE IN MILLIMETERS.	PART NUMBER	REV