

REVISION HISTORY			
REV.	DESCRIPTION	DATE	REVISED BY:

# MRG-062-XXX

## SINGLE STAGE HOLLOW OUTPUT RIGHT ANGLE GEARBOX

0.375" BORE  
(XXX = GEARBOX RATIO)

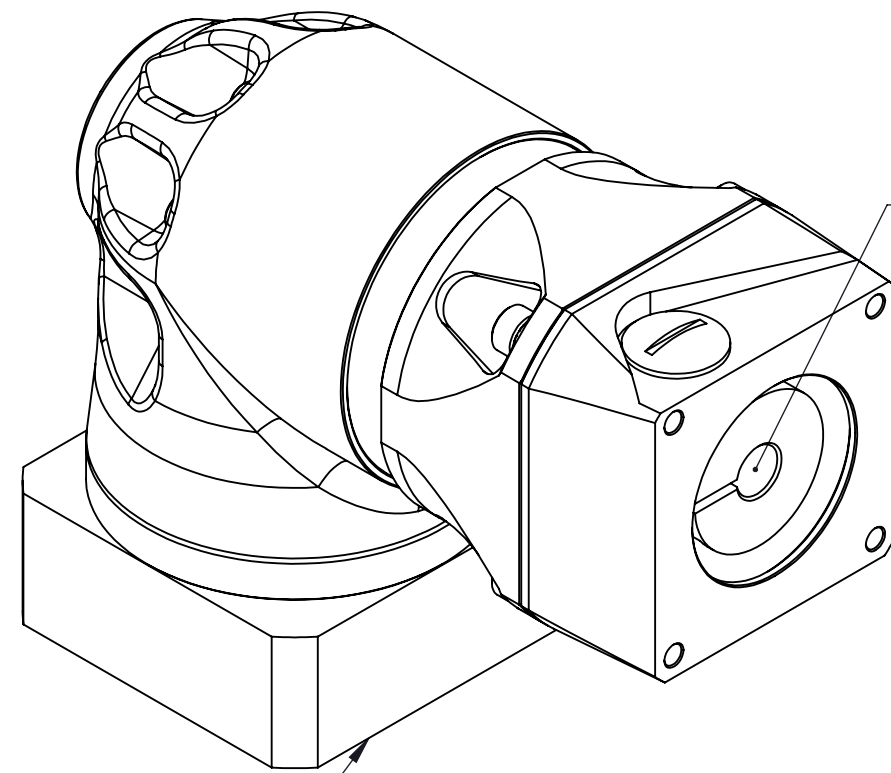

CLAMP SCREW TORQUE SETTING 120 IN.LBS.

MOTOR INPUT SHAFT DIAMETER 14MM MAX  
CLAMP SCREW TORQUE SETTING 53 IN.LBS.

**NOTES:**

- 1.) MOTOR MANUFACTURER AND MODEL NUMBER REQUIRED TO PROPERLY SIZE THE MOTOR ADAPTOR PLATE. MAXIMUM MOTOR INPUT SHAFT DIAMETER IS 14mm.
- 2.) ADAPTOR PLATE SIZE WILL VARY BASED ON MOTOR SPECIFIED. OVERALL DIMENSIONS AND PLATE THICKNESS WILL BE DIFFERENT FROM VISUAL REPRESENTATION ABOVE
- 3.) MOTOR FLANGE BOLT CIRCLE PATTERN AND HOLE DIAMETER ALONG WITH MOTOR SHAFT DIAMETER AND LENGTH WILL DETERMINE THE FINAL SIZE OF THE ADAPTOR PLATE
- 4.) MACRON DYNAMICS, INC. MAKES EVERY EFFORT TO MATCH MOTOR DIMENSIONS TO MOTOR MANUFACTURER'S SPECIFICATIONS. THESE MANUFACTURER'S SPECIFICATIONS CAN CHANGE FROM TIME TO TIME WITHOUT NOTICE. MACRON IS NOT RESPONSIBLE FOR ADAPTORS THAT DO NOT MATE WITH THE MOTORS IF REFERENCE DIMENSIONS HAVE CHANGED OR IF THE USER CHANGES MOTOR MODELS AFTER PURCHASE
- 5.) TIGHTENING THE INPUT AND OUTPUT SCREW CLAMPS TO RECOMMENDED TORQUE IS CRITICAL TO SYSTEM FUNCTION. SHOULD OUTPUT CLAMP SLIP AFTER PROPER TIGHTENING, IT IS POSSIBLE THE MOTOR TORQUE IS EXCEEDING THE GEARBOX SPECIFICATIONS.

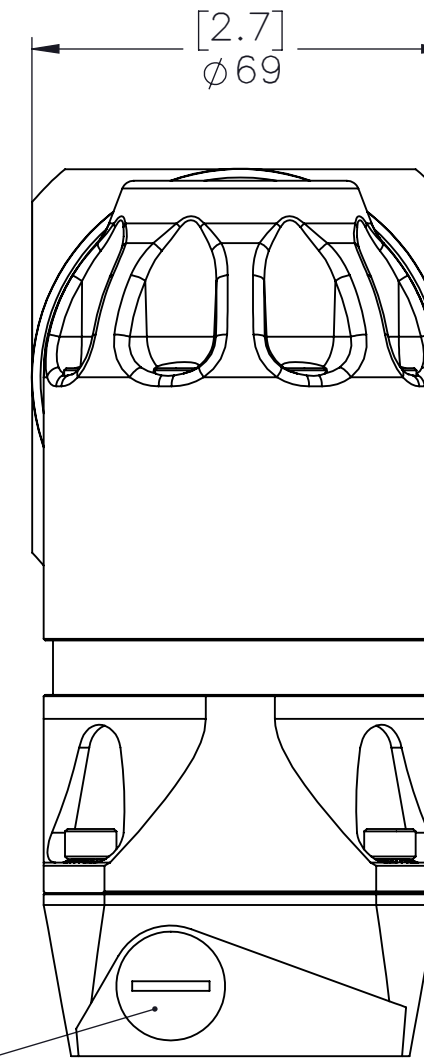

PLUG REF

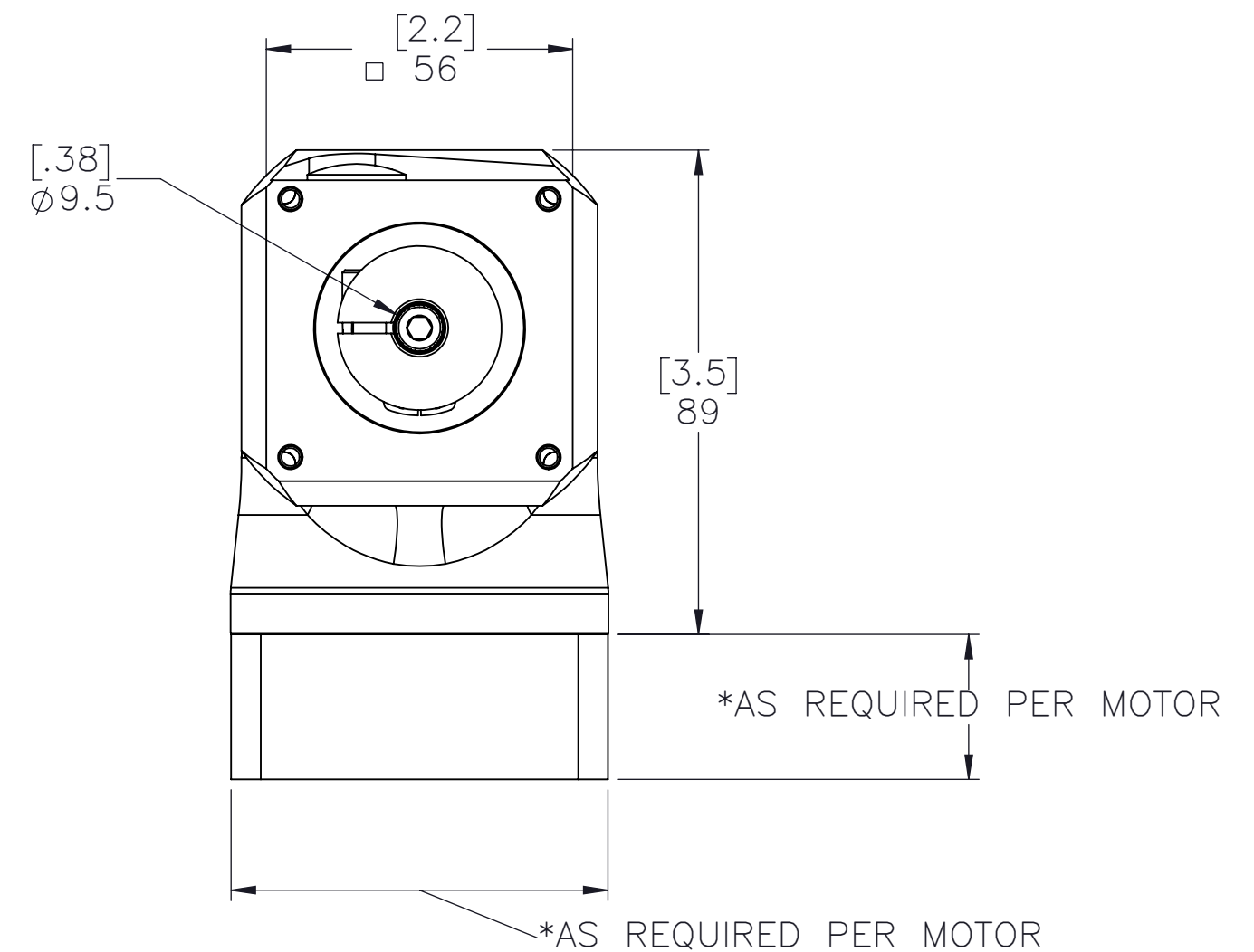

GEARBOX RATIO	3:1	10:1	5:1	7:1
MPG PART NUMBER SUFFIX	003	010	005	007
NOMINAL OUTPUT TORQUE – Nm (lb-in)	14 (124)	14 (124)	22 (195)	22 (195)
MAXIMUM ACCELERATION TORQUE – Nm (lb-in)	25 (221)	21 (186)	37 (327)	37 (327)
NOMINAL INPUT SPEED – RPM	3300	3300	3300	3300
MAXIMUM INPUT SPEED – RPM	6000	6000	6000	6000
STANDARD OUTPUT BACKLASH – arcmin	<12	<12	<12	<12
WEIGHT – kg (lb)	3 (6.6)	3 (6.6)	3 (6.6)	3 (6.6)
MASS MOMENT OF INERTIA – kg/cm2 (lb-in2)	.95 (0.32)	.84 (0.29)	.86 (0.29)	.85 (0.29)
EFFICIENCY AT LOAD	92%	92%	92%	92%
NO LOAD TORQUE – Nm (lb-in)	0.5 (4.4)	0.5 (4.4)	0.5 (4.4)	0.5 (4.4)
DECIBEL RATING	<75	<75	<75	<75



**MACRON DYNAMICS INC**

THIS DRAWING IS THE PROPERTY OF MACRON DYNAMICS. ANY REPRODUCTIONS SHALL BE FOR QUOTATION, MANUFACTURING, OR PURCHASING PURPOSES ONLY. RELEASE OF DRAWINGS TO OTHER CONCERNS DOES NOT CONSTITUTE LICENSING IN ANY WAY. INFORMATION CONTAINED HEREIN IS PROPRIETARY AND CONFIDENTIAL.

DRAWN BY: TH	DATE: 9/18/2018	MATERIAL:
CHECKED BY: --	DATE: DD/MM/YYYY	
LAST SAVED BY: SMulhern	DATE: 7/17/2019	
UNLESS OTHERWISE SPECIFIED, DIMENSIONS ARE IN MILLIMETERS. TOLERANCES UNLESS NOTED OTHERWISE:		FINISH:
.X ± .762	.XX ± .254	
.XXX ± .127	ANG ± 0°30'	

TITLE: MACRON GEARBOX TO 28/12 PULLEY	
SCALE 1:1	SHEET SIZE C
SHEET 1 OF 1	PART NUMBER MRG-062-XXX
REV	01