

MDC-R5D-B-AB- -

PULLEY PITCH DIAMETER	33.42mm (1.316")
PULLEY WIDTH	16.3mm (.642")
PULLEY MATERIAL	STEEL
BELT WEIGHT (kg)	((TRAVEL IN METERS x 2)+.65) x .04
TRAVEL PER REV.	105mm
TRAVEL MIN.	150mm
TRAVEL MAX.	3850mm
CART WEIGHT (kg)	.74 PER CART
SYSTEM WEIGHT (kg)	(TRAVEL IN METERS x 4.6) + 3.2

ENTER
TRAVEL IN INCREMENTS OF 25mm

SELECT
DRIVE SHAFT LOCATION*

SHAFTING TYPE
A0= SINGLE SHAFTED
B0= DOUBLE SHAFTED

NOTE: (IF "B" IS USED THE NUMBER WILL DESIGNATE POSITION OF THE BOSS ON THE PULLEY)

AM= SINGLE SHAFTED W/ MOTOR MOUNT
BM= DOUBLE SHAFTED W/ MOTOR MOUNT

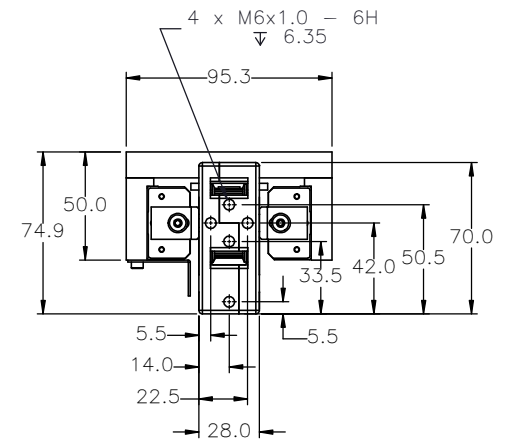
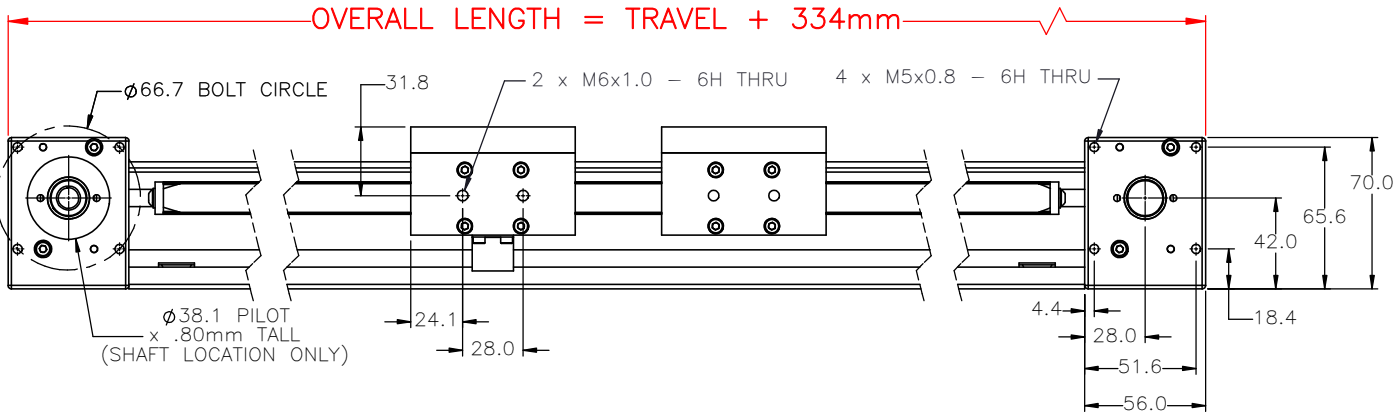
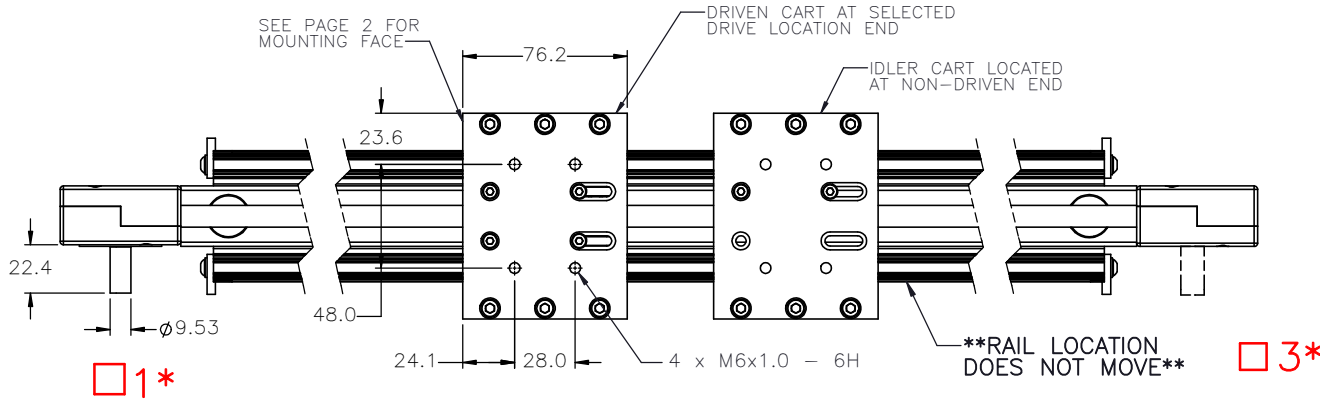
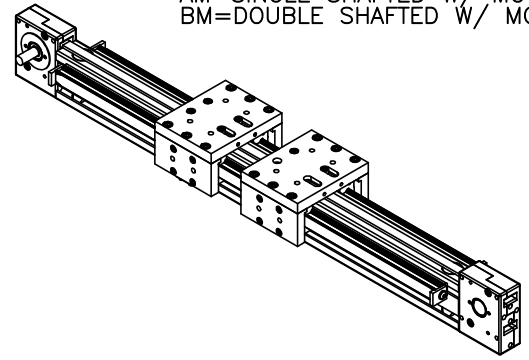

APPROVED: _____

DATE: _____

	DRAWN BY: PHW	DATE: 11/26/2017	MATERIAL:	TITLE: MACRON R5D DUAL CART RAIL ACTUATOR
	CHECKED BY: --	DATE: DD/MM/YYYY	FINISH:	
	LAST SAVED BY: Tim	DATE: 8/3/2020	SHEET:	
	UNLESS OTHERWISE SPECIFIED: DIMENSIONS ARE IN INCHES: TOLERANCES UNLESS NOTED: OTHERWISE:		.X ± .03 .XX ± .010 .XXX ± .005 ANG ± 0°30'	
SURFACE FINISH <input checked="" type="checkbox"/>		BREAK ALL SHARP EDGES DIMENSIONAL LIMITS APPLY AFTER FINISHING		SCALE: 1:1 SHEET SIZE: C
THIRD ANGLE PROJECTION		SHEET: 1 OF 2	PART NUMBER: MDC-R5D	REV:

SPECIFICATIONS ARE SUBJECT TO CHANGE WITHOUT NOTICE

THIS DRAWING IS THE PROPERTY OF MACRON DYNAMICS. ANY REPRODUCTIONS SHALL BE FOR QUOTATION, MANUFACTURING OR PURCHASING PURPOSES ONLY. RELEASE OF DRAWINGS TO OTHER CONCERNS DOES NOT CONSTITUTE LICENSING IN ANY WAY. INFORMATION CONTAINED HEREIN IS PROPRIETARY AND CONFIDENTIAL.

CART MOUNTING FEATURES

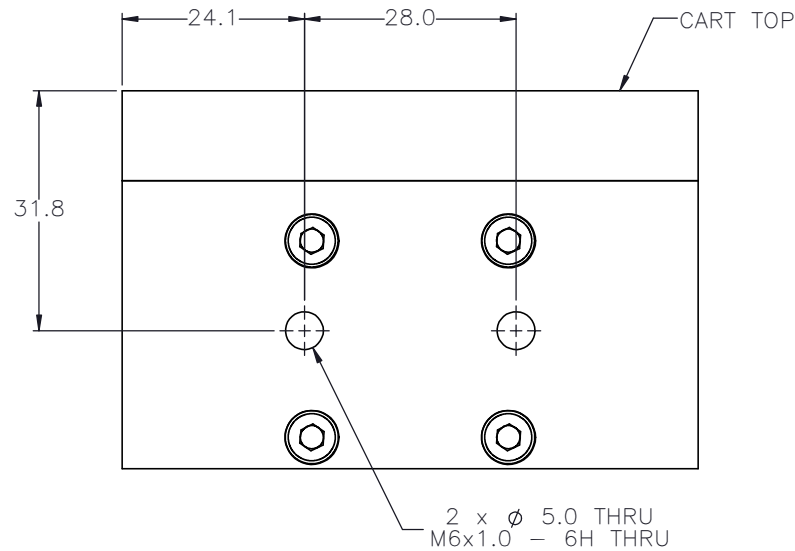

DOUBLE SHAFTED PULLEY

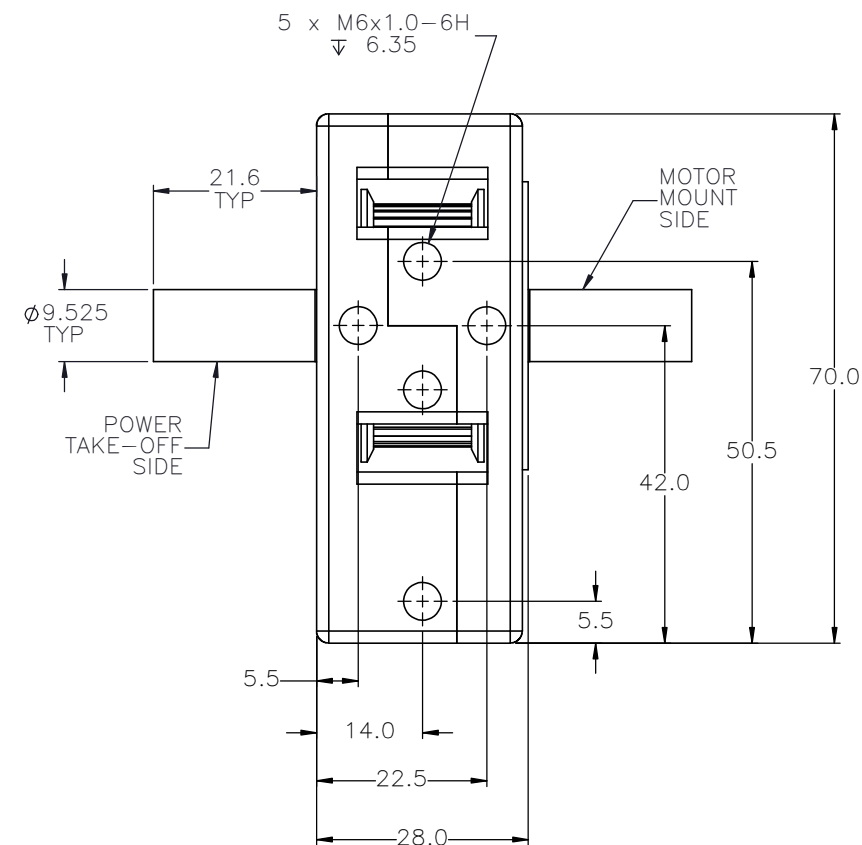
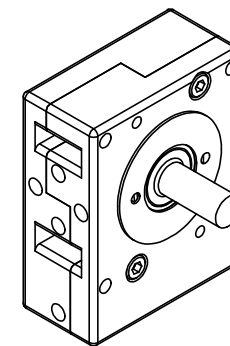

CUSTOMER ACCESSIBLE MOUNTING FEATURES, T-NUT SLOTS

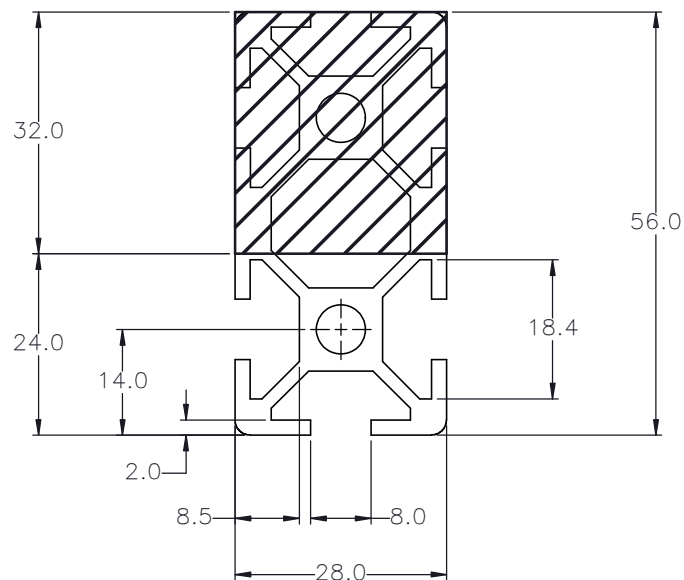

MACRON DYNAMICS INC

DRAWN BY: PHW DATE: 11/26/2017
 CHECKED BY: -- DATE: DD/MM/YYYY
 LAST SAVED BY: Tim DATE: 8/3/2020

MATERIAL:
 FINISH:

TITLE:
 MACRON R5D
 DUAL CART RAIL
 ACTUATOR

THIS DRAWING IS THE PROPERTY OF MACRON DYNAMICS
 ANY REPRODUCTIONS SHALL BE FOR QUOTATION,
 MANUFACTURING OR PURCHASING PURPOSES ONLY.
 RELEASE OF DRAWINGS TO OTHER CONCERNS DOES NOT
 CONSTITUTE LICENSING IN ANY WAY. INFORMATION
 CONTAINED HEREIN IS PROPRIETARY AND CONFIDENTIAL

SURFACE FINISH
 BREAK ALL SHARP EDGES
 DIMENSIONAL LIMITS APPLY AFTER FINISHING
 THIRD ANGLE PROJECTION

SHEET 2 OF 2
 PART NUMBER MDC-R5D

SCALE 1:1 SHEET SIZE C

SPECIFICATIONS ARE SUBJECT TO CHANGE WITHOUT NOTICE