

MAA-R15-B-AB-

PULLEY PITCH DIAMETER	33.42mm (1.316")
PULLEY WIDTH	16.3mm (.640")
PULLEY MATERIAL	STEEL
BELT WEIGHT (kg)	$((\text{TRAVEL IN METERS} \times 2) + .69) \times .04$
TRAVEL PER REV.	105mm
TRAVEL MIN.	150mm
TRAVEL MAX.	3850mm
CART WEIGHT (kg)	.324kg
SYSTEM WEIGHT (kg)	$(\text{TRAVEL IN METERS} \times 3.41) + 1.21$

ENTER
TRAVEL IN INCREMENTS OF 25mm

SELECT
DRIVE SHAFT LOCATION

SHAFTING TYPE
 A0= SINGLE SHAFTED
 B0= DOUBLE SHAFTED
 NOTE: (IF "B" IS USED THE NUMBER WILL DESIGNATE POSITION OF SHORT SHAFT, SECOND SHAFT WILL BE 50.8mm LONG.)
 AM= SINGLE SHAFTED W/ MOTOR MOUNT
 BM= DOUBLE SHAFTED W/ MOTOR MOUNT

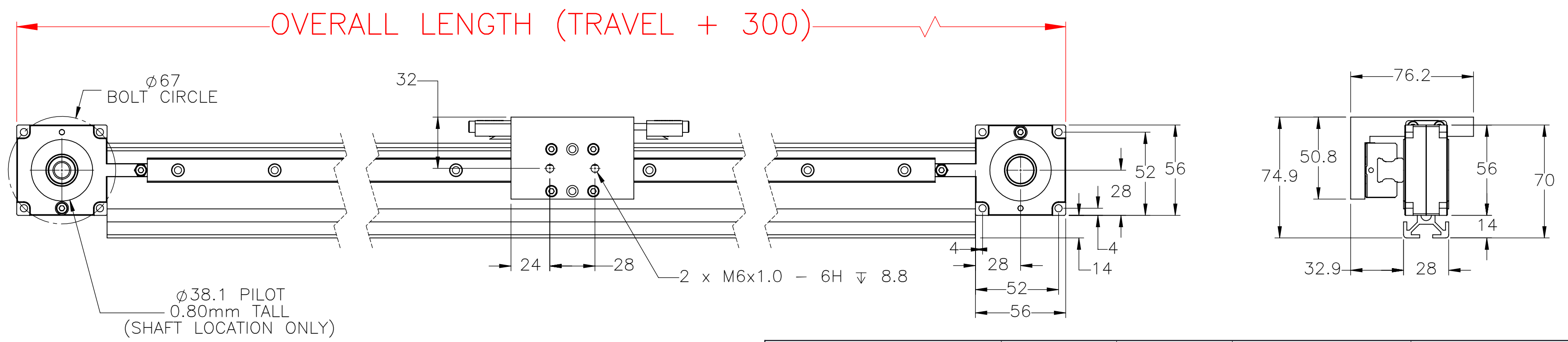
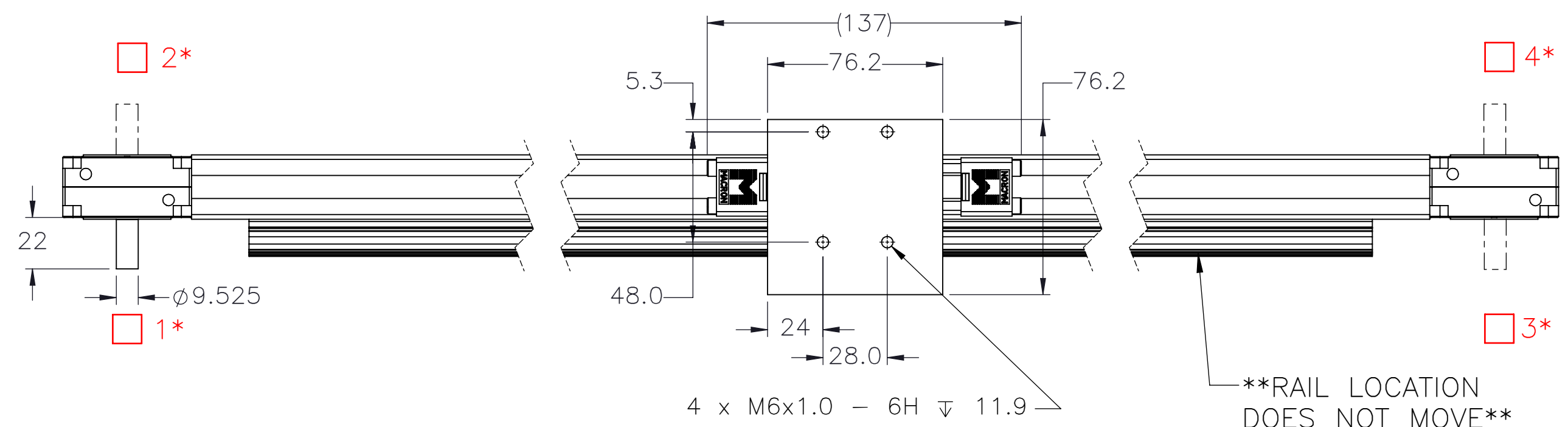
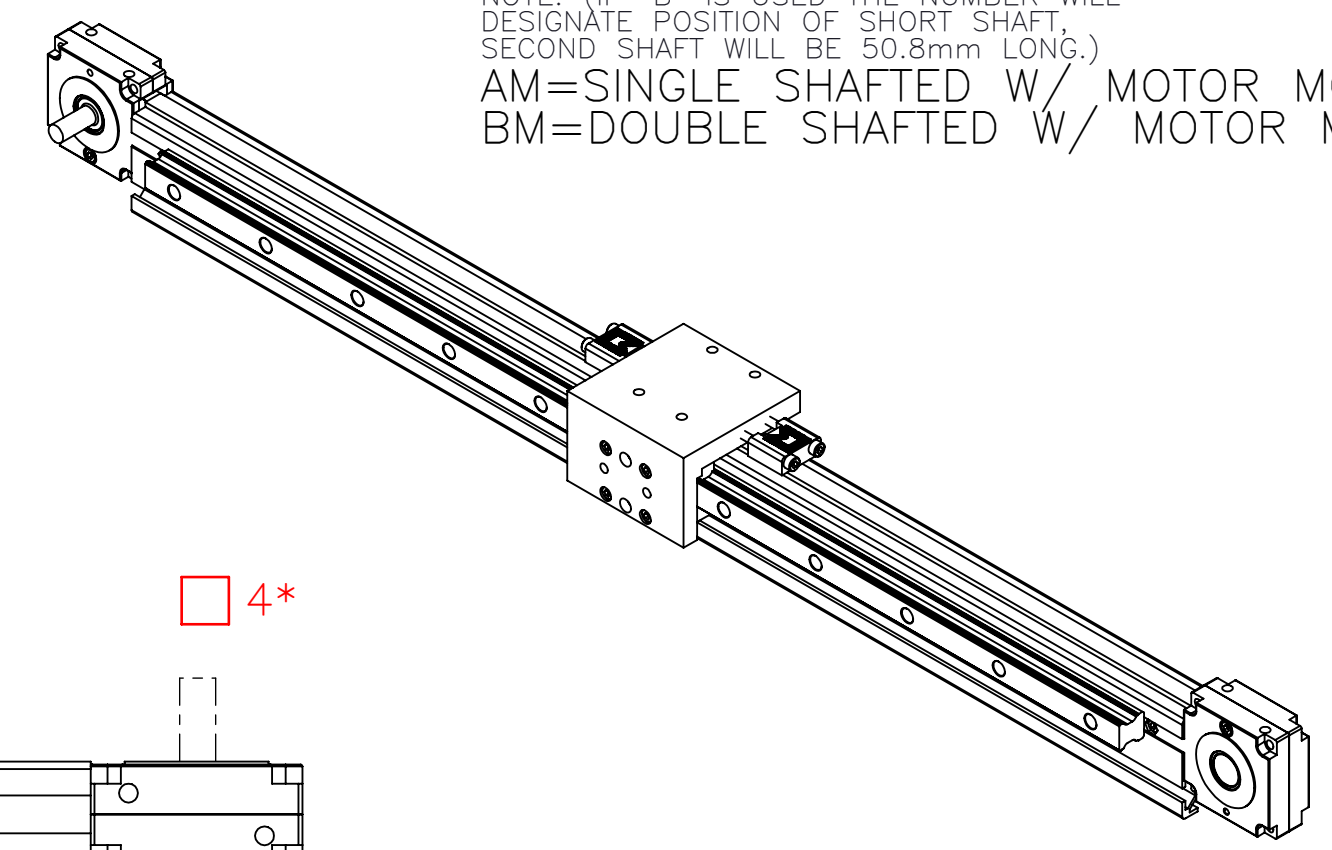

APPROVED: _____

DATE: _____

 MACRON DYNAMICS INC	DRAWN BY: AW DATE: 7/18/2023	MATERIAL:	TITLE: MACRON ACCESS R15
	CHECKED BY: -- DATE: DD/MM/YYYY	FINISH:	
	LAST SAVED BY: tim DATE: 7/20/2023	UNLESS OTHERWISE SPECIFIED, DIMENSIONS ARE IN MILLIMETERS. TOLERANCES UNLESS NOTED OTHERWISE:	
	SURFACE FINISH ∇ 63	.X \pm .762 .XX \pm .254 .XXX \pm .127 ANG \pm 0°30'	
THIS DRAWING IS THE PROPERTY OF MACRON DYNAMICS. ANY REPRODUCTIONS SHALL BE FOR QUOTATION, MANUFACTURING, OR PURCHASING PURPOSES ONLY. RELEASE OF DRAWINGS TO OTHER CONCERNS DOES NOT CONSTITUTE LICENSING IN ANY WAY. INFORMATION CONTAINED HEREIN IS PROPRIETARY AND CONFIDENTIAL.	BREAK ALL SHARP EDGES DIMENSIONAL LIMITS APPLY AFTER FINISHING THIRD ANGLE PROJECTION	SCALE 1:1 SHEET SIZE C	SHEET 1 OF 2 PART NUMBER MAA-R15-B-AB-A01 REV

DOUBLE SHAFTED PULLEY

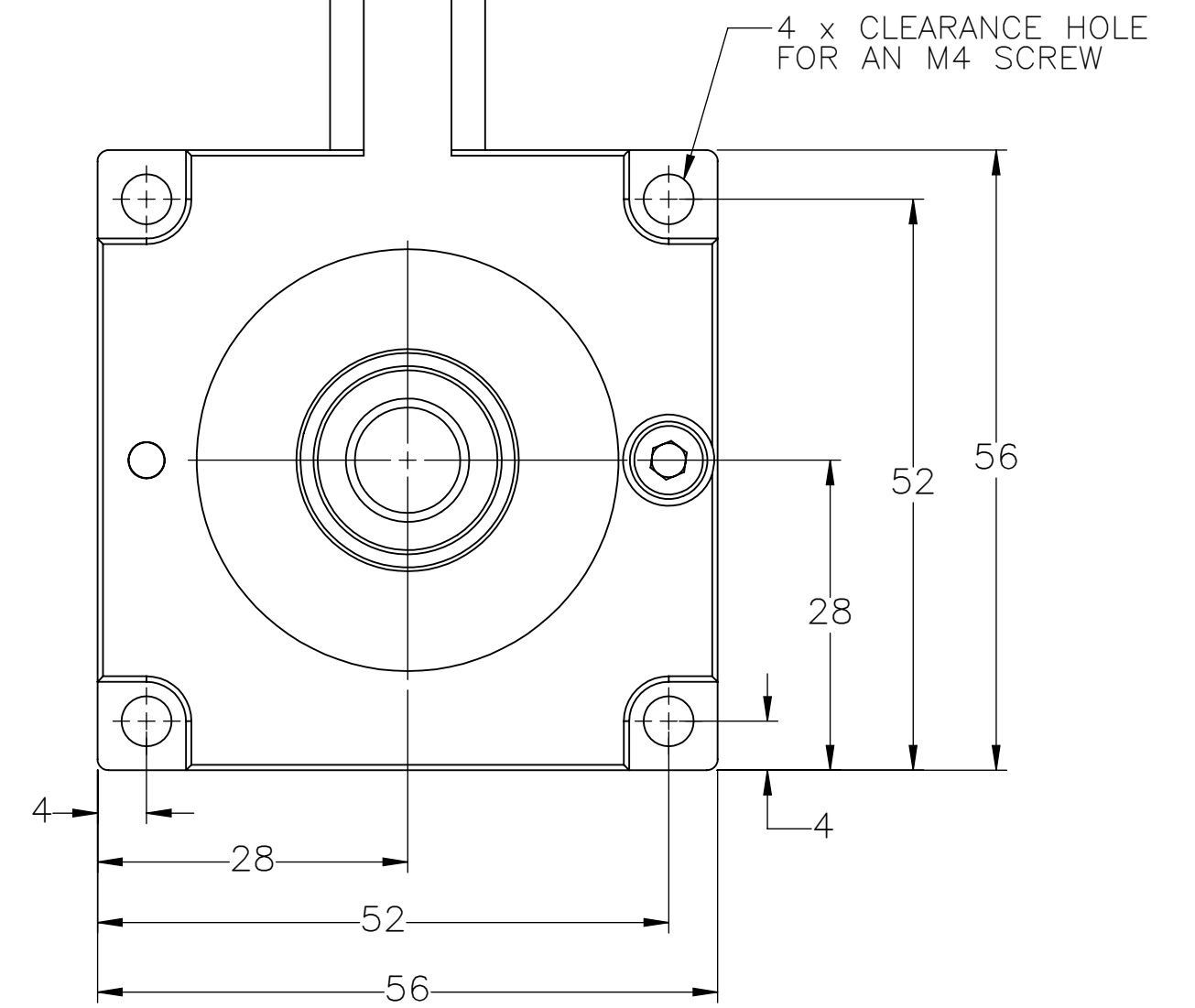
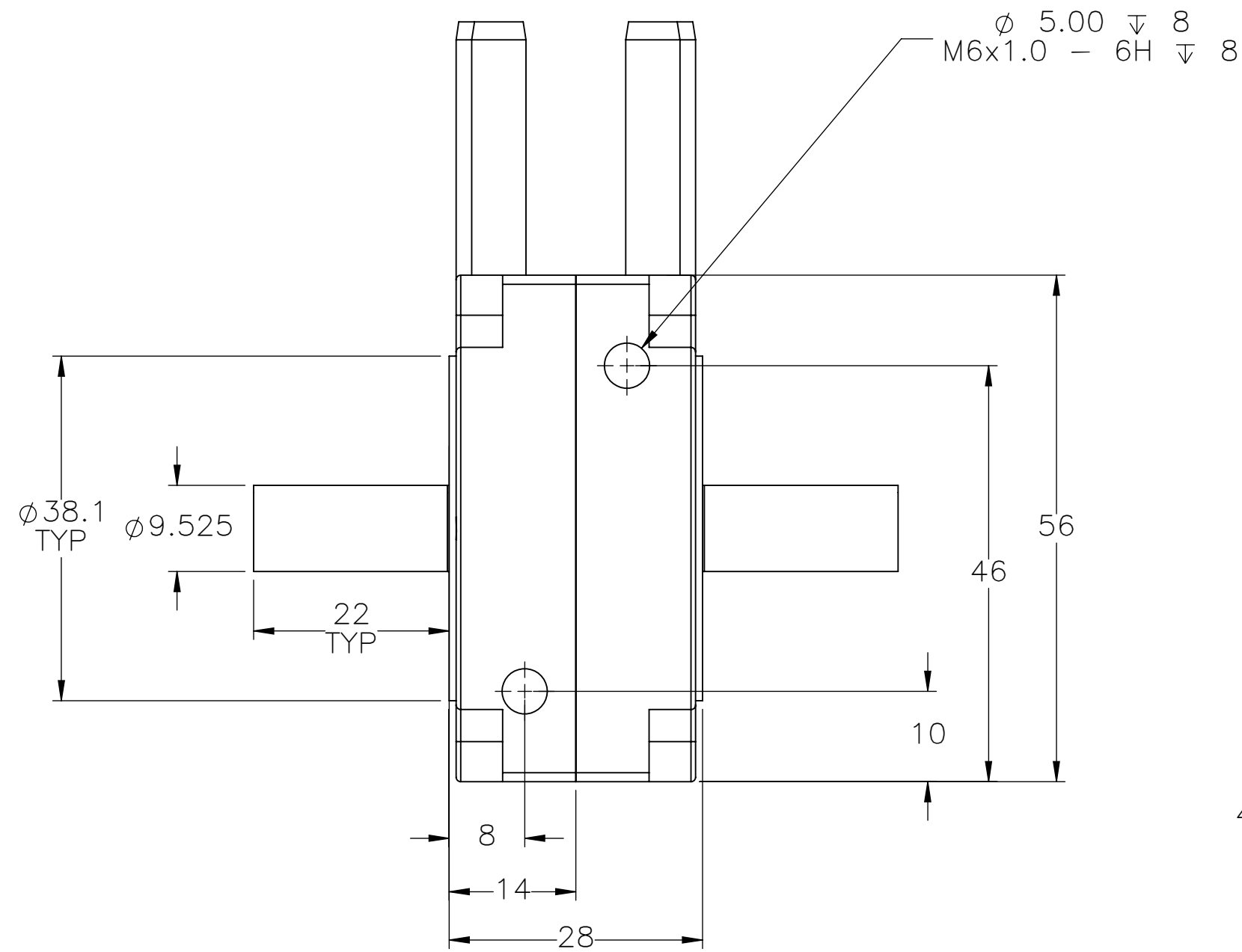
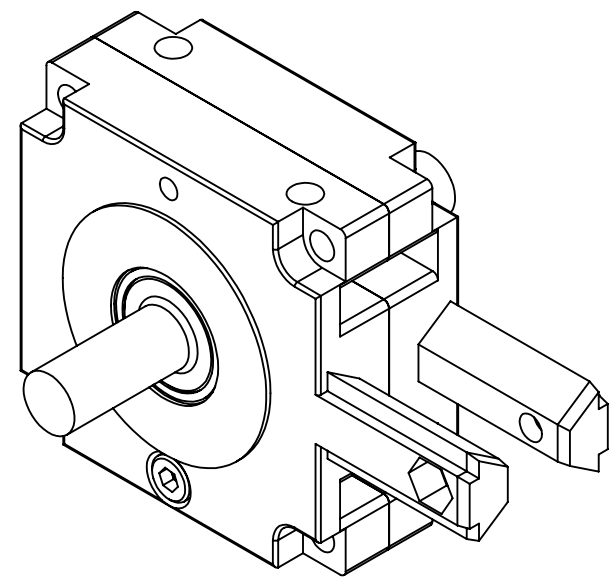

ACTUATOR BODY MOUNTING FEATURES T-NUT SLOTS

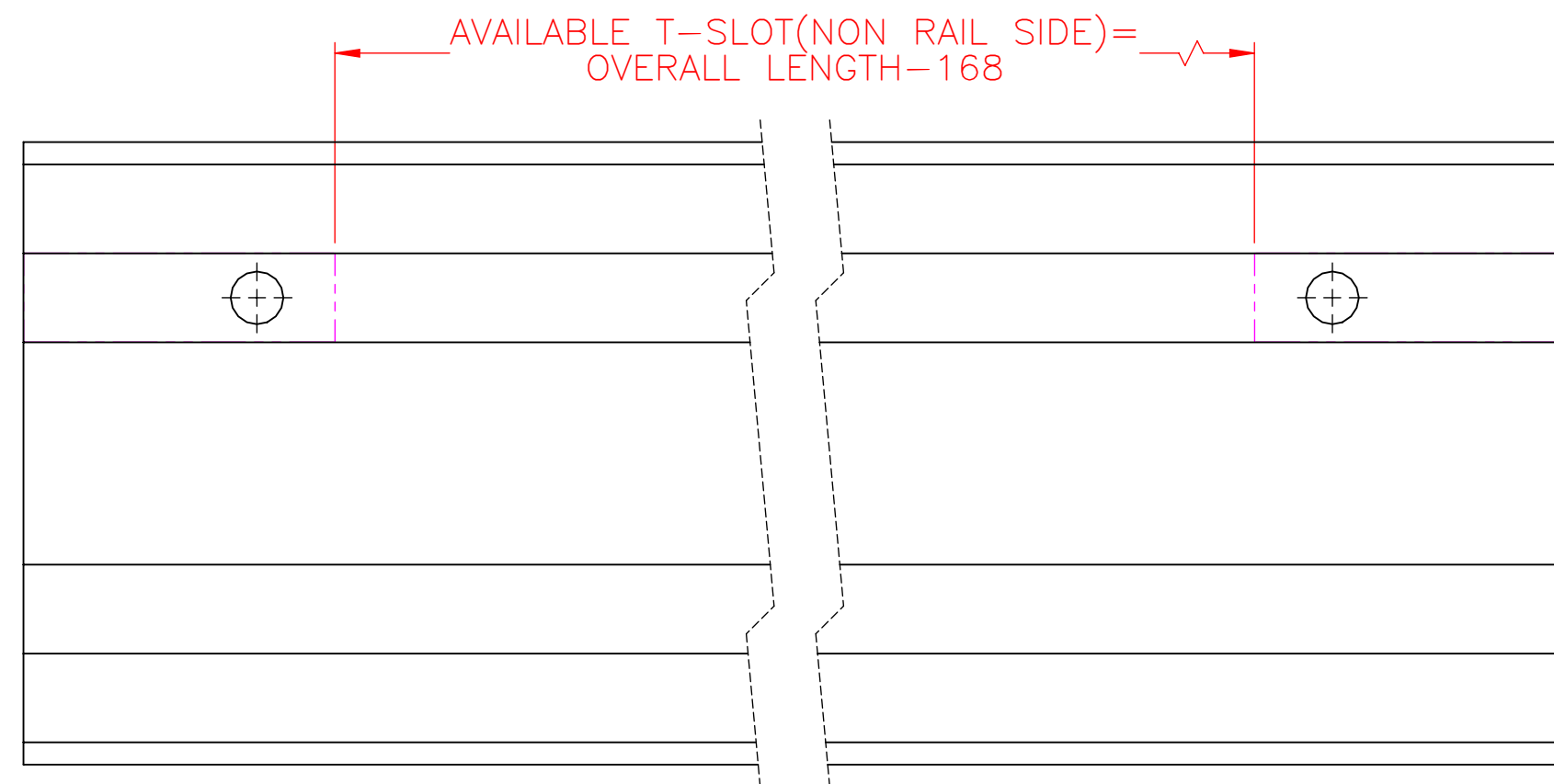
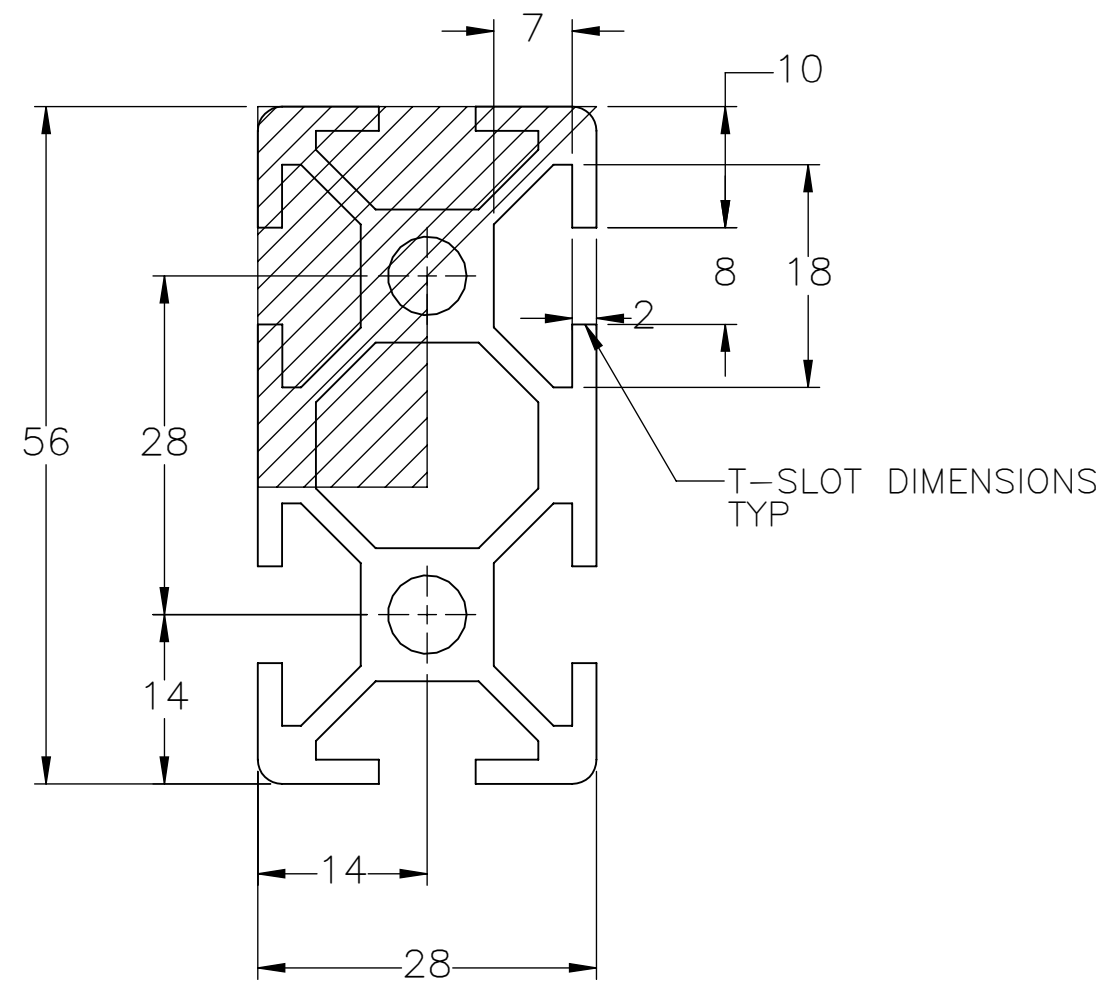

	DRAWN BY: AW CHECKED BY: -- LAST SAVED BY: tim	DATE: 7/18/2023 DATE: DD/MM/YYYY DATE: 7/20/2023	MATERIAL:	TITLE:
	UNLESS OTHERWISE SPECIFIED, DIMENSIONS ARE IN MILLIMETERS. TOLERANCES UNLESS NOTED OTHERWISE:	.X \pm .762 .XX \pm .254 .XXX \pm .127 ANG \pm 0°30'	FINISH:	MACRON ACCESS ACTUATOR
THIS DRAWING IS THE PROPERTY OF MACRON DYNAMICS. ANY REPRODUCTIONS SHALL BE FOR QUOTATION, MANUFACTURING, OR PURCHASING PURPOSES ONLY. RELEASE OF DRAWINGS TO OTHER CONCERNS DOES NOT CONSTITUTE LICENSING IN ANY WAY. INFORMATION CONTAINED HEREIN IS PROPRIETARY AND CONFIDENTIAL.	SURFACE FINISH 63	BREAK ALL SHARP EDGES DIMENSIONAL LIMITS APPLY AFTER FINISHING	SCALE 1:1 SHEET SIZE C	SHEET 2 OF 2
THIRD ANGLE PROJECTION	PART NUMBER	MAA-R15	REV	