

# MSA-SB5-G-BE-

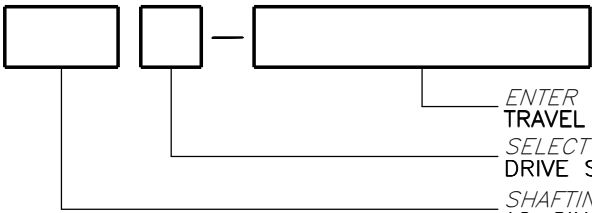

PULLEY PITCH DIAMETER	47.75mm (1.880")
PULLEY WIDTH	54.0mm (2.124")
PULLEY MATERIAL	STEEL
BELT WEIGHT	.0133 lb/in or 6.0g/25mm
TRAVEL PER REV.	150mm
TRAVEL MIN.	150mm
TRAVEL MAX.	5775mm

ENTER  
TRAVEL IN INCREMENTS OF 25mm

SELECT  
DRIVE SHAFT LOCATION\*

SHAFTING TYPE  
AO=SINGLE SHAFTED  
BO=DOUBLE SHAFTED  
AM=SINGLE SHAFTED W/ MOTOR MOUNT  
BM=DOUBLE SHAFTED W/ MOTOR MOUNT

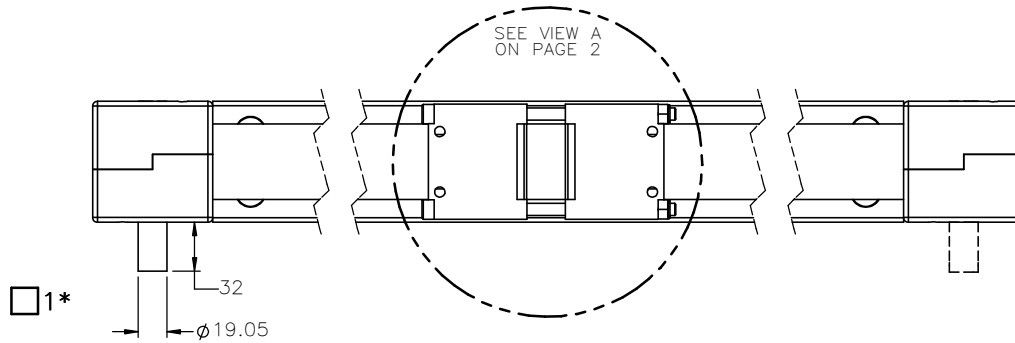
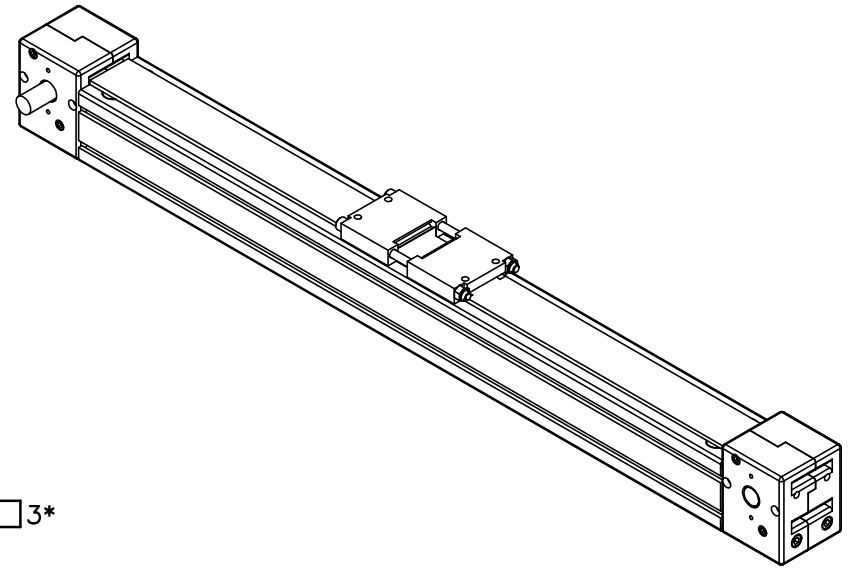

□ 1\*

□ 3\*

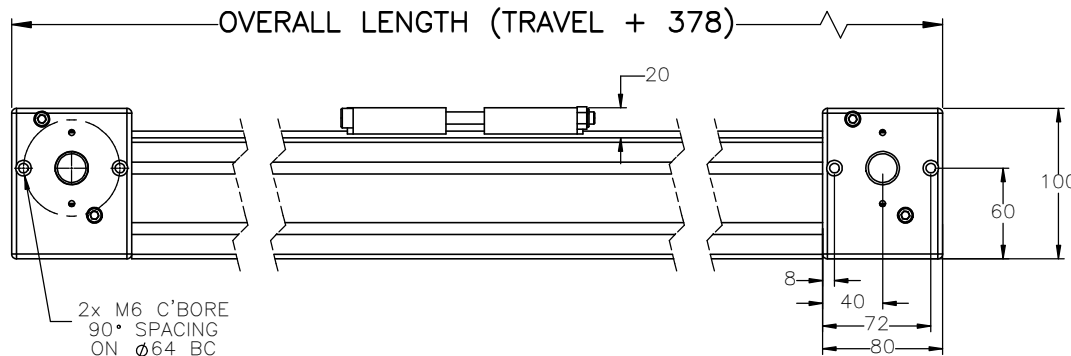

2 x M8x1.25 - 6H  
▽14

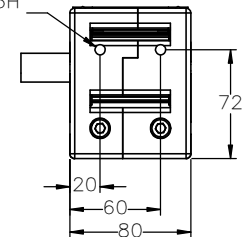

APPROVED: \_\_\_\_\_

DATE: \_\_\_\_\_



MACRON DYNAMICS INC

DRAWN BY: ASB	DATE: 3/6/2012	MATERIAL:
CHECKED BY: --	DATE: DD/MM/YYYY	
LAST SAVED BY: Tim	DATE: 4/25/2017	
UNLESS OTHERWISE SPECIFIED: DIMENSIONS ARE IN MILLIMETER TOLERANCES UNLESS NOTED OTHERWISE:		FINISH:
.X ± .762		
.XX ± .254		
.XXX ± .127		
ANG ± 0°30'		

TITLE:  
MACRON SINGLE  
BELT DRIVE 50

SURFACE FINISH ✓  
BREAK ALL SHARP EDGES  
DIMENSIONAL LIMITS APPLY AFTER FINISHING  
THIRD ANGLE PROJECTION

SHEET  
1 OF 2

PART NUMBER  
MSA-SB5  
SCALE 1:1 SHEET SIZE C  
REV  
01

SPECIFICATIONS ARE SUBJECT TO CHANGE WITHOUT NOTICE

THIS DRAWING IS THE PROPERTY OF MACRON DYNAMICS  
ANY REPRODUCTIONS SHALL BE FOR QUOTATION,  
MANUFACTURING, OR PURCHASING PURPOSES ONLY.  
RELEASE OF DRAWINGS TO OTHER CONCERNS DOES NOT  
CONSTITUTE LICENSING IN ANY WAY. INFORMATION  
CONTAINED HEREIN IS PROPRIETARY AND CONFIDENTIAL

# ACTUATOR BODY MOUNTING FEATURES T-NUT SLOTS

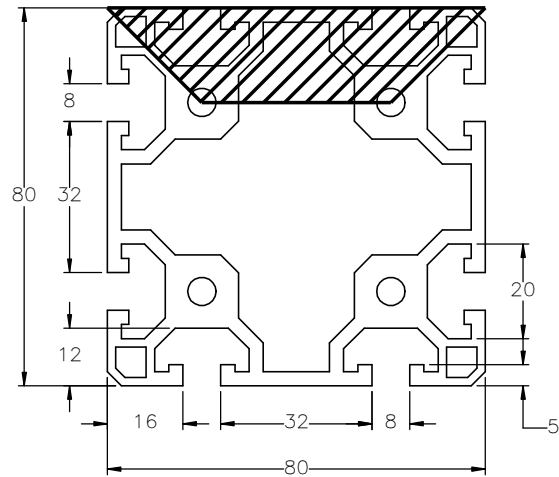

# DETAILED CART VIEW A

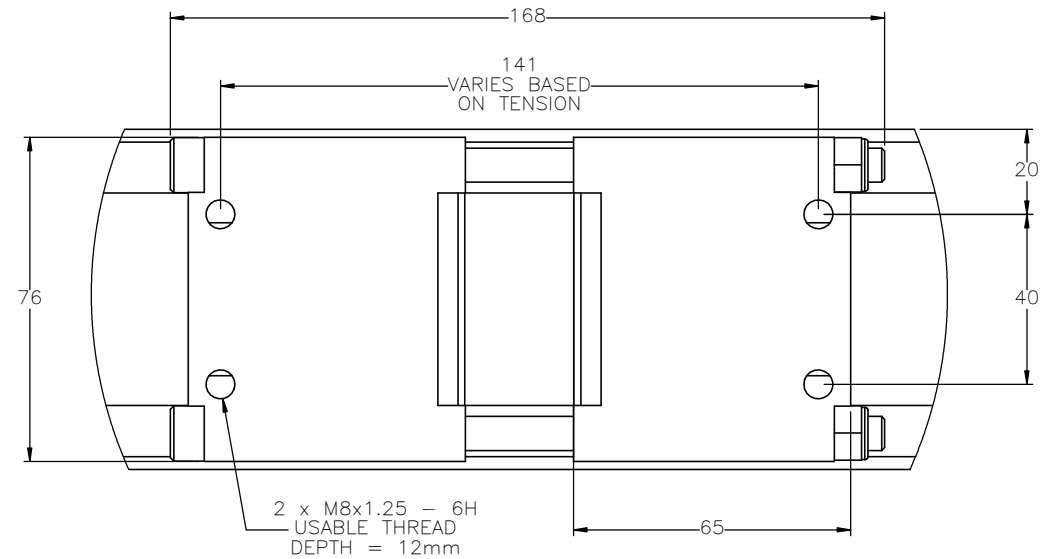

# DOUBLE SHAFTED PULLEY

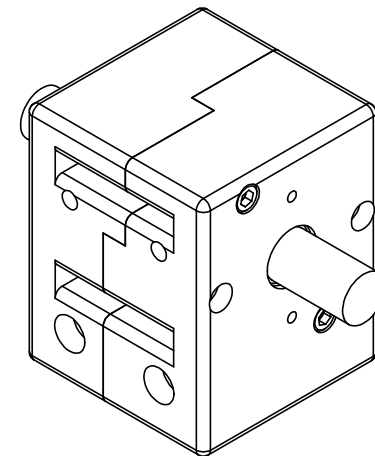
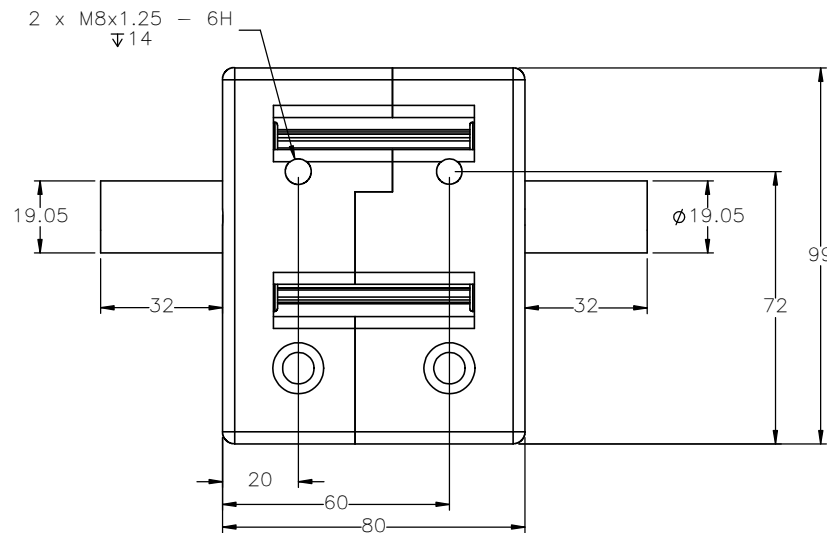

 <b>MACRON DYNAMICS INC</b>	DRAWN BY: ASB CHECKED BY: -- LAST SAVED BY: Tim	DATE: 3/6/2012 DATE: DD/MM/YYYY DATE: 4/25/2017	MATERIAL:	TITLE: MACRON SINGLE BELT DRIVE 50
	UNLESS OTHERWISE SPECIFIED: DIMENSIONS ARE IN MILLIMETER TOLERANCES UNLESS NOTED OTHERWISE:		FINISH:	SCALE: 1:1 SHEET SIZE: c
	SURFACE FINISH: <input checked="" type="checkbox"/> BREAK ALL SHARP EDGES DIMENSIONAL LIMITS APPLY AFTER FINISHING		SHEET: 2 OF 2 PART NUMBER:	REV: 01
	THIS DRAWING IS THE PROPERTY OF MACRON DYNAMICS. ANY REPRODUCTIONS SHALL BE FOR QUOTATION, MANUFACTURING, OR PURCHASING PURPOSES ONLY. RELEASE OF DRAWINGS TO OTHER CONCERNS DOES NOT CONSTITUTE LICENSING IN ANY WAY. INFORMATION CONTAINED HEREIN IS PROPRIETARY AND CONFIDENTIAL.		SPECIFICATIONS ARE SUBJECT TO CHANGE WITHOUT NOTICE	