

REVISION HISTORY			
REV.	DESCRIPTION	DATE	REVISED BY:

MPG-064-XXX

SINGLE STAGE HOLLOW OUTPUT PLANETARY GEARBOX

0.750" BORE
(XXX = GEARBOX RATIO)

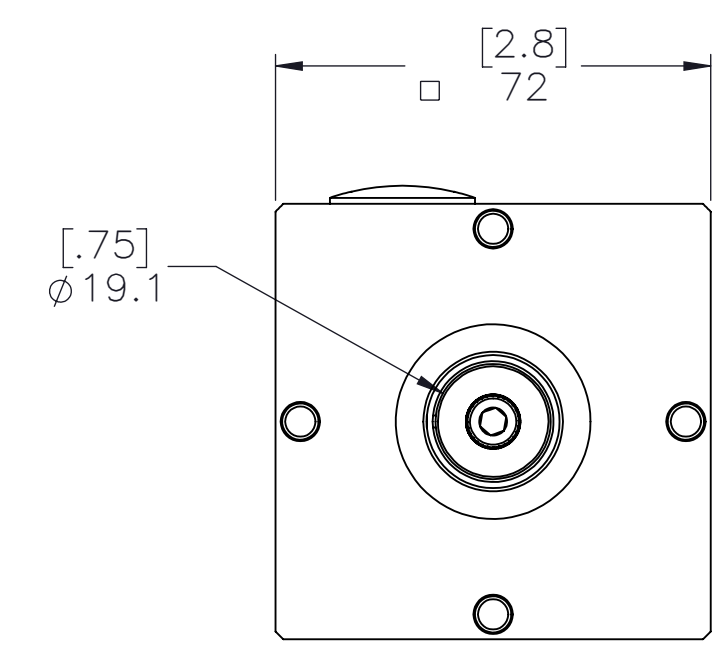
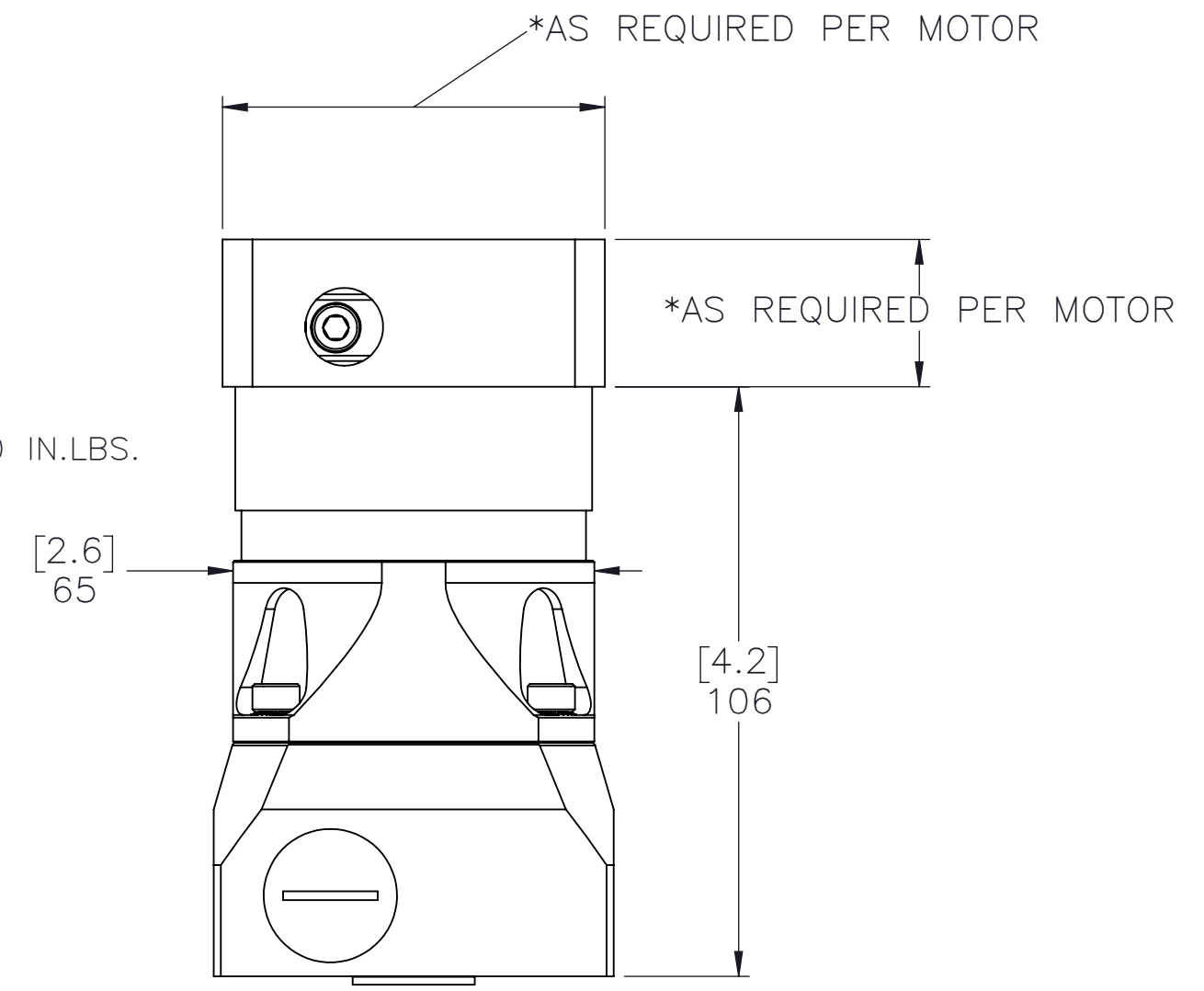
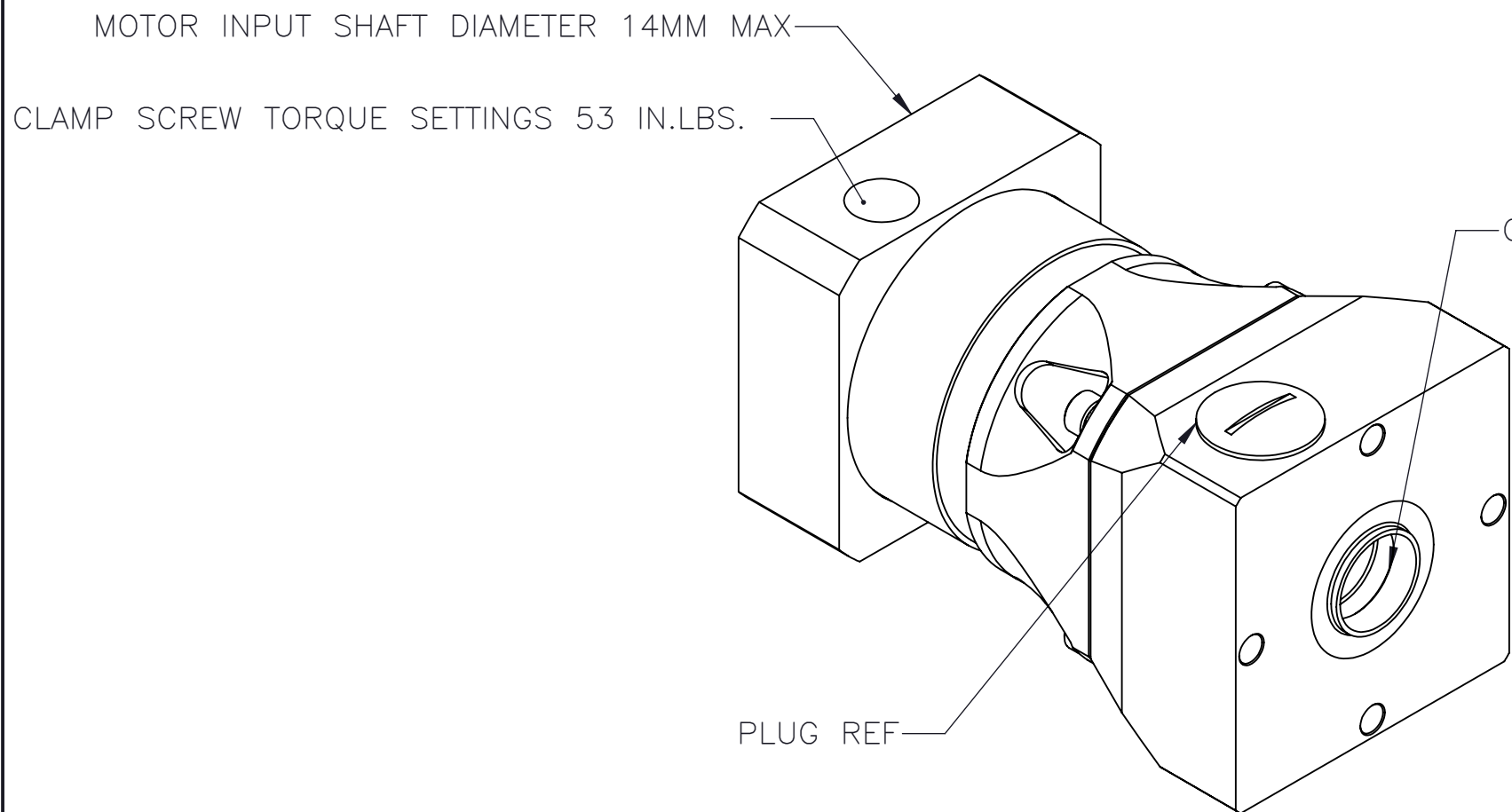

- NOTES:
- 1.) MOTOR MANUFACTURER AND MODEL NUMBER REQUIRED TO PROPERLY SIZE THE MOTOR ADAPTOR PLATE. MAXIMUM MOTOR INPUT SHAFT DIAMETER IS 14mm.
 - 2.) ADAPTOR PLATE SIZE WILL VARY BASED ON MOTOR SPECIFIED. OVERALL DIMENSIONS AND PLATE THICKNESS WILL BE DIFFERENT FROM VISUAL REPRESENTATION ABOVE
 - 3.) MOTOR FLANGE BOLT CIRCLE PATTERN AND HOLE DIAMETER ALONG WITH MOTOR SHAFT DIAMETER AND LENGTH WILL DETERMINE THE FINAL SIZE OF THE ADAPTOR PLATE
 - 4.) MACRON DYNAMICS, INC. MAKES EVERY EFFORT TO MATCH MOTOR DIMENSIONS TO MOTOR MANUFACTURER'S SPECIFICATIONS. THESE MANUFACTURER'S SPECIFICATIONS CAN CHANGE FROM TIME TO TIME WITHOUT NOTICE. MACRON IS NOT RESPONSIBLE FOR ADAPTORS THAT DO NOT MATE WITH THE MOTORS IF REFERENCE DIMENSIONS HAVE CHANGED OR IF THE USER CHANGES MOTOR MODELS AFTER PURCHASE
 - 5.) TIGHTENING THE INPUT AND OUTPUT SCREW CLAMPS TO RECOMMENDED TORQUE IS CRITICAL TO SYSTEM FUNCTION. SHOULD OUTPUT CLAMP SLIP AFTER PROPER TIGHTENING, IT IS POSSIBLE THE MOTOR TORQUE IS EXCEEDING THE GEARBOX SPECIFICATIONS.

GEARBOX RATIO	3:1	10:1	5:1	7:1
MPG PART NUMBER SUFFIX	003	010	005	007
NOMINAL OUTPUT TORQUE – Nm (lb-in)	14 (124)	14 (124)	26 (230)	26 (230)
MAXIMUM ACCELERATION TORQUE – Nm (lb-in)	25 (221)	25 (221)	40 (354)	40 (354)
NOMINAL INPUT SPEED – RPM	3500	3500	3500	3500
MAXIMUM INPUT SPEED – RPM	6000	6000	6000	6000
STANDARD OUTPUT BACKLASH – arcmin	<10	<10	<10	<10
WEIGHT – kg (lb)	1 (2.2)	1 (2.2)	1 (2.2)	1 (2.2)
MASS MOMENT OF INERTIA – kg/cm2 (lb-in2)	.45 (0.154)	.34 (0.116)	.36 (0.123)	.35 (0.120)
EFFICIENCY AT LOAD	92%	92%	92%	92%
NO LOAD TORQUE – Nm (lb-in)	0.5 (4.4)	0.5 (4.4)	0.5 (4.4)	0.5 (4.4)
DECIBEL RATING – dB	<66	<66	<66	<66



MACRON DYNAMICS INC

DRAWN BY: TH DATE: 9/18/2018 MATERIAL:

CHECKED BY: -- DATE: DD/MM/YYYY

LAST SAVED BY: TH DATE: 7/17/2019

UNLESS OTHERWISE SPECIFIED, DIMENSIONS ARE IN MILLIMETERS. TOLERANCES UNLESS NOTED OTHERWISE:

.X ±	.762
.XX ±	.254
.XXX ±	.127
ANG ±	0°30'

TITLE: **MACRON GEARBOX TO 40/25 PULLEY**

SCALE 1:1 SHEET SIZE C

THIS DRAWING IS THE PROPERTY OF MACRON DYNAMICS. ANY REPRODUCTIONS SHALL BE FOR QUOTATION, MANUFACTURING, OR PURCHASING PURPOSES ONLY. RELEASE OF DRAWINGS TO OTHER CONCERNS DOES NOT CONSTITUTE LICENSING IN ANY WAY. INFORMATION CONTAINED HEREIN IS PROPRIETARY AND CONFIDENTIAL.

SURFACE FINISH \checkmark
BREAK ALL SHARP EDGES
DIMENSIONAL LIMITS APPLY AFTER FINISHING
THIRD ANGLE PROJECTION

SHEET 1 OF 1

PART NUMBER MPG-064-XXX

REV 01