

MSA-135-0-BC---

PULLEY PITCH DIAMETER	47.75mm (1.880")
PULLEY WIDTH	28.9mm (1.138")
PULLEY MATERIAL	STEEL
BELT WEIGHT	.0063 lb/in or 2.9g/25mm
TRAVEL PER REV.	150mm
TRAVEL MIN.	150mm
TRAVEL MAX.	5600mm

ENTER TRAVEL IN INCREMENTS OF 25mm
SELECT DRIVE SHAFT LOCATION*

SHAFTING TYPE
A0= SINGLE SHAFTED
B0= DOUBLE SHAFTED
NOTE: (IF "B" IS USED THE NUMBER WILL DESIGNATE POSITION OF SHORT SHAFT. SECOND SHAFT WILL BE 50.8mm LONG.)
AM= SINGLE SHAFTED W/ MOTOR MOUNT
BM= DOUBLE SHAFTED W/ MOTOR MOUNT

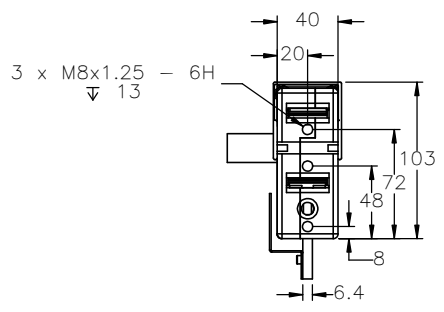
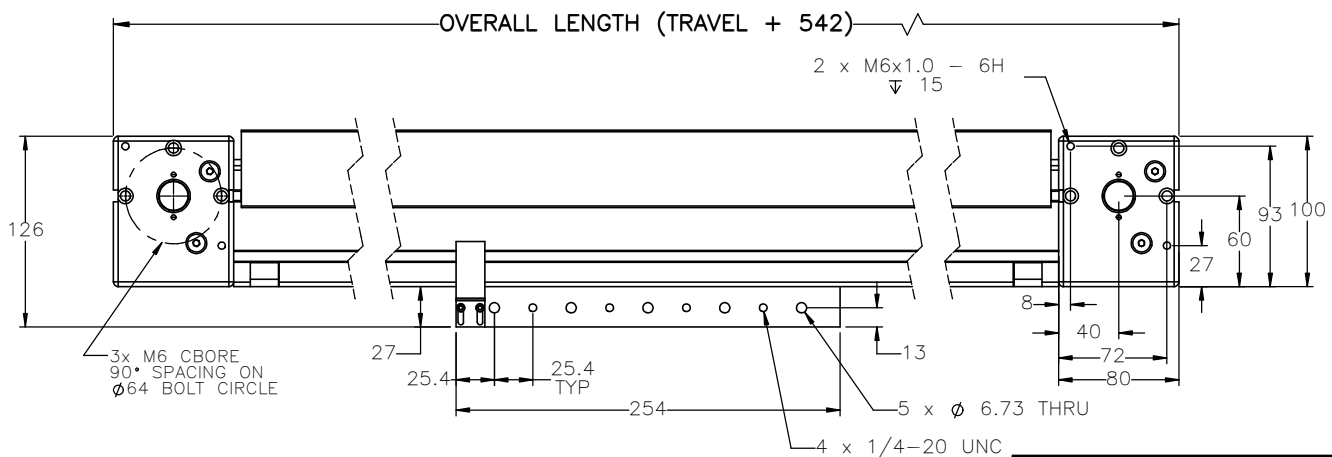
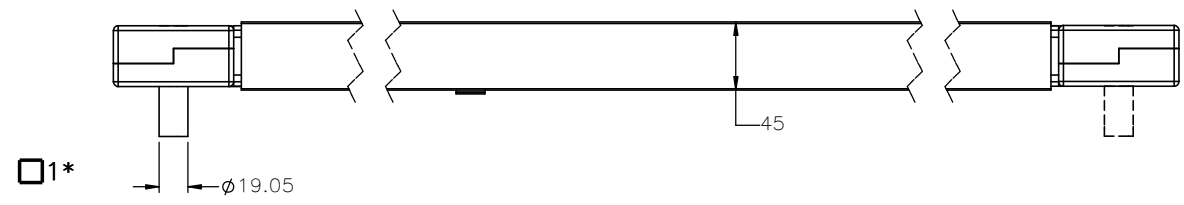
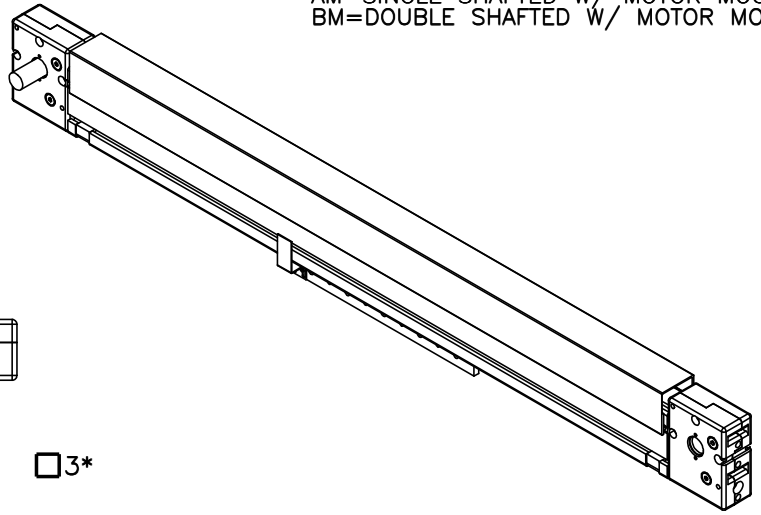

APPROVED: _____
DATE: _____

 MACRON DYNAMICS INC	DRAWN BY: ASB DATE: 3/6/2012 CHECKED BY: --- DATE: DD/MM/YYYY LAST SAVED BY: Tim DATE: 4/25/2017	MATERIAL:	TITLE: MACRON 135 ACTUATOR	
	UNLESS OTHERWISE SPECIFIED: DIMENSIONS ARE IN MILLIMETER TOLERANCES UNLESS NOTED OTHERWISE: .X ± .762 .XX ± .254 .XXX ± .127 ANG ± 0°30'	FINISH:	SCALE: 1:1 SHEET SIZE: C	
	SURFACE FINISH: <input checked="" type="checkbox"/> BREAK ALL SHARP EDGES DIMENSIONAL LIMITS APPLY AFTER FINISHING THIRD ANGLE PROJECTION	SHEET: 1 OF 2	PART NUMBER: MSA-135	REV: 01
	THIS DRAWING IS THE PROPERTY OF MACRON DYNAMICS. ANY REPRODUCTIONS SHALL BE FOR QUOTATION, MANUFACTURING, OR PURCHASING PURPOSES ONLY. RELEASE OF DRAWINGS TO OTHER CONCERNS DOES NOT CONSTITUTE LICENSING IN ANY WAY. INFORMATION CONTAINED HEREIN IS PROPRIETARY AND CONFIDENTIAL.			

SPECIFICATIONS ARE SUBJECT TO CHANGE WITHOUT NOTICE

CUSTOMER ACCESSIBLE MOUNTING FEATURES, T-NUT SLOTS

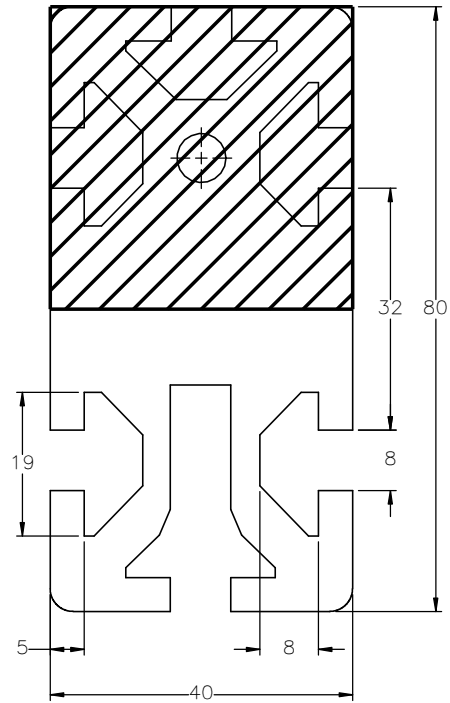

DOUBLE SHAFTED PULLEY

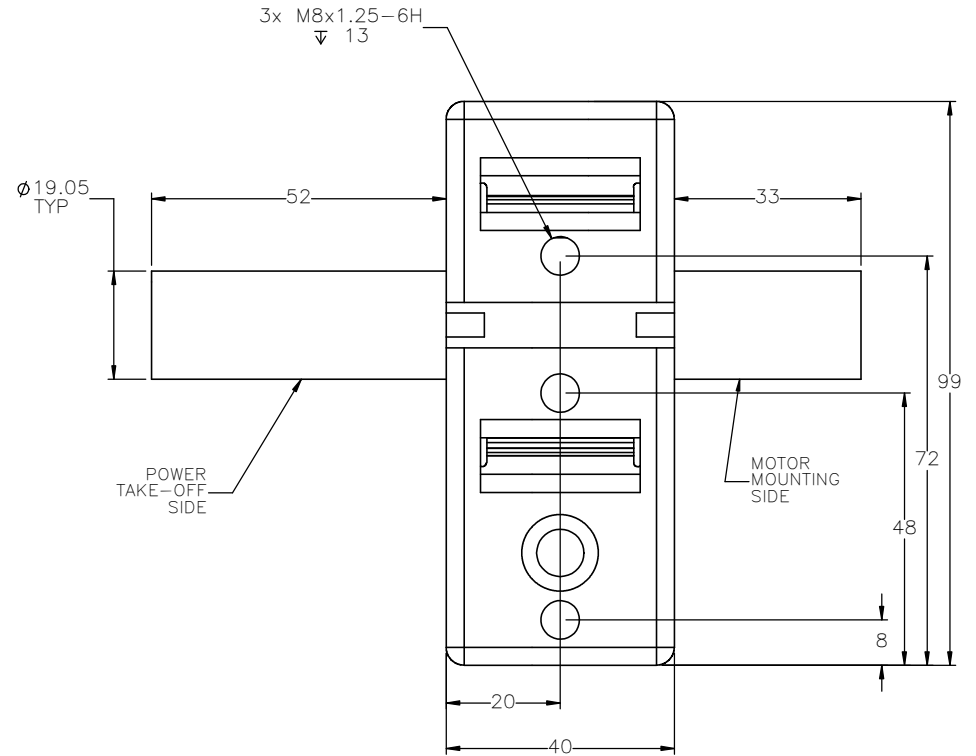
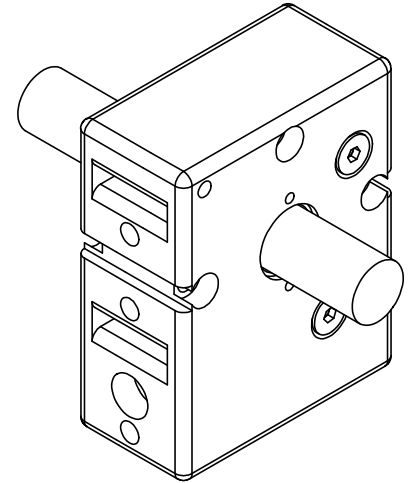

 MACRON DYNAMICS INC	DRAWN BY: ASB CHECKED BY: -- LAST SAVED BY: Tim	DATE: 3/6/2012 DATE: DD/MM/YYYY DATE: 4/25/2017	MATERIAL:	TITLE: MACRON 135 ACTUATOR
	UNLESS OTHERWISE SPECIFIED: DIMENSIONS ARE IN MILLIMETER TOLERANCES UNLESS NOTED OTHERWISE: .X ± .762 .XX ± .254 .XXX ± .127 ANG ± 0°30'		FINISH:	SCALE: 1:1 SHEET SIZE: C
	SURFACE FINISH: <input checked="" type="checkbox"/>		SHEET: 2 OF 2	PART NUMBER: MSA-135
	THIS DRAWING IS THE PROPERTY OF MACRON DYNAMICS. ANY REPRODUCTIONS SHALL BE FOR QUOTATION, MANUFACTURING OR PURCHASING PURPOSES ONLY. RELEASE OF DRAWINGS TO OTHER CONCERNS DOES NOT CONSTITUTE LICENSING IN ANY WAY. INFORMATION CONTAINED HEREIN IS PROPRIETARY AND CONFIDENTIAL.		BREAK ALL SHARP EDGES DIMENSIONAL LIMITS APPLY AFTER FINISHING THIRD ANGLE PROJECTION	REV: 01

SPECIFICATIONS ARE SUBJECT TO CHANGE WITHOUT NOTICE